

The ACT Group Flash Air Cannon



Operator's Manual



Flash Cannon G400 Series Air Cannons

Installation and Operating Instructions

TABLE OF CONTENTS

I. INTRODUCTION	2
What is an Air Cannon	
Applications	
Safety Precautions	
II. AIR CANNON OPERATION	3
General Overview - How the Air Cannon Works	
Air Requirements	
Air Filtration	
Lubrication	
When to "Fire" the Air Cannon	
Methods of Control - Manual vs. Automatic	
Operation Use of a Quick Exhaust Valve	
Required Accessories	
Test Firing the Air Cannon	
III. INSTALLATION	7
Preparation and Background	
Visual Inspection	
Temporary Plug Removal	
Installing Discharge Pipe	
Mounting the Air Cannon to the Discharge Pipe	
General Piping Instructions for Air Cannon System	
Air Control Components Air Cannon Control Component Installation	
IV. AIR CANNON START-UP PROCEDURES	18
V. MAINTENANCE	19
VI. DISASSEMBLY AND ASSEMBLY OF THE AIR CANNON	19
Dismounting the Air Cannon	
Removing the Internal Valve	
Valve Disassembly	
Valve Inspection	
Assembling the Valve	
Assembling the Air Cannon	
Testing the Air Cannon	
Mounting the Air Cannon	
<u>APPENDIX A</u> - Troubleshooting	24
<u>APPENDIX B</u> - System Recommendations	25
<u>APPENDIX C</u> - Air Cannon Dimensions	28
<u>APPENDIX D</u> - Air Cannon Plumbing Diagrams	29
<u>APPENDIX E</u> - Air Cannon Performance Data	30
<u>APPENDIX F</u> - Air Cannon Parts Drawings	31
<u>APPENDIX G</u> - Coordinates & Dimensions of Elliptical Openings for Tangential Mounts ...	33
<u>APPENDIX H</u> - Mounting G400 Air Cannons on High Temperature Applications	34



G400 Series Air Cannons Installation and Operating Instructions



SECTION I - INTRODUCTION

This manual will assist in the installation and operation of *Flash Cannon G400 Series* direct blast Air Cannons. Please read the entire manual to assure proper installation, operation, and maintenance of this equipment. These instructions apply to the following models:

- 1-**G400-40-50**: 4" discharge with 12" x 28" (50 liter) pressure vessel
- 2-**G400-40-150**: 4" discharge with 20" x 30" (150 liter) pressure vessel
- 3-**G400-60-300**: 6" discharge with 24" x 48" (300 liter) pressure vessel
- 4-**G400-60-650**: 6" discharge with 30" x 60" (650 liter) pressure vessel

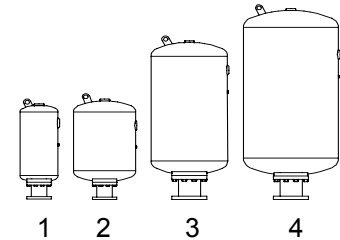

What is an Air Cannon?

ACT Flash Cannon Air Cannons are direct blast aerators consisting of a compressed air reservoir with a quick opening valve that releases the stored air in a sudden, high energy blast. This blast is directed through a discharge pipe to restore material flow by aerating and dislodging material that is bridging, arching, rat holing, or clinging.

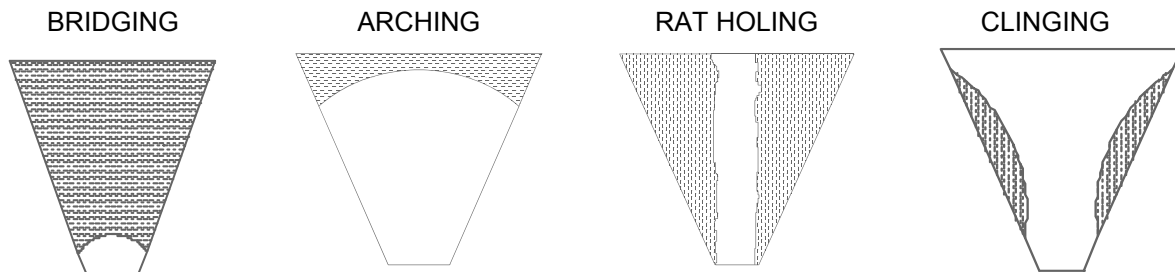

The direct blast design allows the stored air in the reservoir to escape directly into the discharge pipe without bends or obstructions that could impede the flow of air. This is important because the quicker the air discharges, the greater the velocity and force of the blast and, therefore, the greater the amount of material affected. Air Cannons are activated manually or by a micro-controller based sequencing timer which controls the firing time interval and sequence of one or more Air Cannons. Applied Conveyor Technology offers two lines of direct blast aerators, the **GW Series** for general use (ambient temperatures below 130°F or 55°C) and the **G400 Series** for high temperature applications (ambient temperatures up to 400°F or 200°C) such as cement kilns and steel mills where internal kiln temperatures can be as high as 2,000°F or 1,100°C.

Applications:

Air Cannons easily solve bulk flow problems in silos, hoppers, chutes, and storage piles. They are used where vibration is not practical, or when other methods are too expensive, dangerous, or destructive. Air Cannons are recommended for a wide range of material clogs and jams, and are well suited for large structures of any type. They are commonly used when it is impractical to physically shake stuck material loose, and are effective for very cohesive, difficult materials. For instance, large concrete bunkers and storage piles on the ground are impossible to vibrate, but are common locations of flow problems. Wood chips are very difficult to dislodge by other means, but respond very well to the quick-release Air Cannons. Air Cannons are also used to periodically aerate material sitting in bins, hoppers, and silos since their blast will lift and separate the material rather than compact it.



G400 Series Air Cannons Installation and Operating Instructions



Safety Precautions:

The air blast can *exceed 1,000 ft/sec (300 m/sec) and 1,500 lbs (680 kg) of force*. Be sure to read and follow all safety precautions.

DANGER

- ⇒ Do not stand in front of any Air Cannon during discharge. The air blast can cause serious injury.
- ⇒ Use of an Air Cannon to shoot a projectile may cause serious injury or death.

WARNING

- ⇒ ACT Flash Cannon Air Cannon pressure vessels are ASME code welded and certified. Do not weld onto the pressure vessel (tank). Welding to the tank will void ASME certification and may cause vessel malfunction.
- ⇒ All OSHA, ANSI and owner's safety procedures and regulations must be followed during installation, operation, and maintenance of Air Cannons.
- ⇒ Do not discharge Air Cannon into open air without clear warnings to all persons in the area.
- ⇒ All Air Cannons must be empty of air when being transported, mounted, or inspected.
- ⇒ Due to recoil, do not discharge an Air Cannon that is not securely mounted to a structure.
- ⇒ Mount Air Cannons securely on Schedule 40 pipe or equivalent. If structure is not sufficiently rigid to support the Air Cannon, obtain special mount hardware from your distributor.
- ⇒ Attach the ring on the end of the Air Cannon tank to a structural support with a safety cable to prevent the Air Cannon from falling if its supports were to give way.
- ⇒ Do not enter application structure (i.e. bin or hopper) if Air Cannons are pressurized and ready to be discharged.

CAUTION

- ⇒ Do not allow the internal pressure in a closed storage vessel to exceed its limitations when the Air Cannons are fired. This may cause damage to the storage vessel. Install exhaust vents if pressures exceed 0.5 psi (0.034 bar). The momentary vessel pressure following the firing of an Air Cannon can be estimated as follows:

$$P_m = \frac{\text{Air Cannon tank pressure (psi or atm)} \times \text{Air Cannon tank volume (ft}^3 \text{ or liters)}}{\text{Air Cannon tank volume (ft}^3 \text{ or liters)} + \text{Structure volume (ft}^3 \text{ or liters)}}$$

- ⇒ G400 Series Flash Cannon Air Cannons can withstand 400°F (200°C). Exposure to temperatures greater than 400°F will cause the piston to seize. Damage caused by operating G400 Air Cannons at temperatures in excess of 400°F are not covered by the product warranty. When used on kilns with temperatures of 2,000°F (1,100°C), the discharge pipe should be at least 36" long and contain at least one long radius bend. See APPENDIX H.

SECTION II - AIR CANNON OPERATION

General Overview—How the Air Cannon Works:

Each Cannon is charged with compressed air through an air inlet controlled by a 3-way normally open valve (either a manual valve or a solenoid valve). Once filled, the Air Cannon remains charged as long as pressure to the tank is maintained by pressure in the fill line. To fire the Air Cannon, pressure in the fill line is suddenly reduced by switching the 3-way valve, evacuating the air in the fill line to the atmosphere. Re-switching the 3-way valve will restore plant air allowing the Air Cannon to refill. A step-by-step



G400 Series Air Cannons Installation and Operating Instructions



outline of the filling and discharging process follows:

1. A 3-way valve in the open position allows plant air to enter the Air Cannon. The pressure of the plant air insures an air tight seal between the piston and seat, preventing any air loss while Air Cannon is waiting to be fired.
2. Plant air is forced out through the check valve in the valve cap to fill the pressure vessel with air.
3. Once filled, the Air Cannon remains on standby waiting to be fired.
4. When the 3-way valve is switched, air in the fill line is exhausted, causing the air pressure at the back of the piston to drop.
5. Due to the pressure differential created, the tank pressure forces the piston back into the open position.
6. The compressed air in the pressure vessel escapes through the discharge in an explosive blast that lifts and separates material particles, restoring material flow.
7. The 3-way valve is re-switched allowing the plant air to re-charge the Air Cannon.
8. The pressure of the plant air forces the piston to close against the valve seat preventing contaminants from entering the Air Blaster.

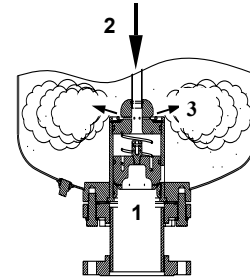

CANNON FILLED AND IN STANDBY

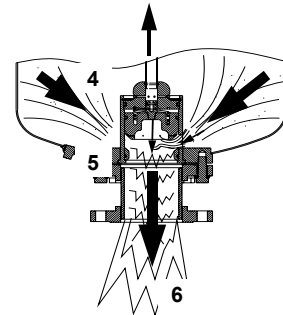

AIR CANNON DISCHARGING

Air Requirements:

For optimum performance, operate the Air Cannon on filtered, regulated air between 45 and 125 psi (3-8.5 bar). The pressure may be adjusted to obtain the desired amount of blast force (generally 80-100 psi). Refer to the performance data in Appendix E to see how the blast force varies with air pressure and to determine the quantity of air needed to fill the Air Cannon for each pressure level. A standard air compressor can be used, however, nitrogen, carbon dioxide or another inert gas can be used in place of the normal air supply. The Air Cannon pressure vessel has a 125 psi pressure relief valve (safety valve) which can be used to completely exhaust the compressed air inside the tank without firing the Air Cannon.

Air Filtration:

Use filtered (40 Micron) compressed air to fill and operate the Air Cannon.

Lubrication:

Flash Cannon Air Cannons require no lubrication.

When to "Fire" the Air Cannon:

It is best to discharge the Air Cannon only when a material flow problem occurs. Firing too often when the storage vessel discharge is closed is not recommended. A group of Air Cannons may be fired se-quentially using the *Flash Cannon Master* micro-controller based sequencing timer.



G400 Series Air Cannons Installation and Operating Instructions



Quick Exhaust Valve:

The Air Cannon is discharged by reducing the pressure in the internal valve assembly. The quicker the pressure drop occurs, the faster the Air Cannon piston opens, therefore the faster and more forceful the air blast. To obtain optimum Air Cannon performance (maximize the force for the air pressure being used), the device used for exhausting the fill line should be as close to the Air Cannon as possible. G400 Series Air Cannons come standard with ACT's G-Series quick exhaust valve permanently mounted. This patent pending valve was designed specifically for use with Global Air Cannon. It quickly evacuates air from the Air Blaster valve, guaranteeing a full, powerful blast even when the control valve is up to 100' from the Air Cannon. This unique valve also insures closure of the Air Cannon valve immediately af-ter the blast. This feature of immediate valve closure, without the use of a spring, is unique to Flash Cannon G400 Air Cannon. Other manufacturers use a spring which can break and cause down time.

Methods of Control - Manual vs. Automatic Operation:

Flash Air Cannon operation can be controlled either *manually* or *automatically*:

Manual Operation: For strictly manual operation the Air Cannon is controlled by a **3-way non-mally open manual valve**. This type of valve has 3 ports - an inlet to connect to the air source, an outlet to connect to the Air Cannon quick exhaust valve, and an exhaust port. A 3/4" valve is used for all G400 models. The manual 3-way valve is placed in the "open" position to fill the Air Cannon and to keep it pressurized in a standby, ready-to-fire mode. To discharge the Air Cannon, the valve is moved to the "closed" position, which exhausts the air in the fill line between the valve and the Air Cannon quick exhaust valve. This sudden decrease in line pressure triggers the quick exhaust valve which fires the Air Cannon. The valve should be returned to the "open" position to refill the Air Cannon for its next use.

Automatic Operation: For automatic operation the Air Cannon is controlled by a **3-way non-mally open solenoid valve**. It has 3 ports - an inlet to connect to the air source, an outlet to connect to the Air Cannon quick exhaust valve, and an exhaust port. A 3/4" Solenoid is used for all G400 models. The solenoid is controlled electronically using a Flash *Master Blaster* timer or a manually triggered momentary electric switch. When not energized, the solenoid valve is "open", allowing the Air Cannon to fill with air. The Air Cannon will remain pressurized in a standby, ready-to-fire mode as long as the solenoid valve is open. To discharge the Air Blaster, the solenoid is energized by the timer or switch closure. This closes the solenoid valve, which exhausts the air in the fill line between the solenoid and the Air Cannon quick exhaust valve. This sudden decrease in line pressure triggers the quick exhaust valve which fires the Air Cannon. The timer or opening of the switch de-energizes the solenoid, the valve re-opens and the Air Cannon is re-filled for its next use.

Required Accessories:

This manual includes instructions for installing a complete Air Cannon system. The following air control components are necessary for Flash Cannon G400 Series Air Cannons to be fully operational. They are avail-able from Applied Conveyor Technology:

1. **Shut-off Ball Valve:** A 2-way shut-off ball valve is used to isolate the Air Cannon system from the plant air supply. Install it between the plant air supply and all other components in the Air Blaster system. **Clearly label and locate the shut-off valve where it can be quickly and easily reached in an emergency or for routine maintenance.** Use one shut-off valve for each filter-regulator-gauge used in the system. A 1/2" or larger valve is recommended for all Air Cannon models.



G400 Series Air Cannons Installation and Operating Instructions



2. **Filter-Regulator-Gauge:** The filter-regulator-gauge (FRG) protects the Air Cannon and airline components by filtering water and particulate contaminants from the air supply. It also is used to control the force output of the Air Cannon by regulating the air pressure (determines the volume of air stored in the Air Cannon pressure vessel). For optimum performance drain the filter reservoir of the FRG daily. For this reason, an FRG that drains automatically may be desired. We recommend using one (1) FRG for every four (4) Air Cannons. A 1/2" or larger FRG is recommended for all Air Cannon models.
3. **Airline Check Valve:** The airline check valve prevents accidental firing of the Air Cannon due to pressure loss in the main supply line. If the main airline loses pressure, the check valve maintains pressure to the Air Cannon by preventing backward air flow. Use one check valve for every Air Cannon, and install it between the FRG and the 3-way control valve. A 1/2" or larger check valve is recommended for all Air Cannon models.
4. **3-Way Control Valve:** The 3-way control valve controls the firing of the Air Cannon. When in the open position, the Air Cannon is filled with air and maintained in the standby, ready-to-fire mode. When closed, the Air Cannon is discharged. A 3/4" valve can be used and located up to 100 feet from the Air Cannon for all models **when the recommended quick exhaust valve is also used** (see below). For manual firing only, use a manual valve. For automatic firing, use a solenoid valve. When no quick exhaust valve is used, it is recommended the 3-way normally open valve be placed within 10 feet of the Air Cannon. The size of the valve should be increased to 1" for the G400-60-300 and G400-60-650 models.
5. **Quick Exhaust Valve:** G400 Series Air Cannons come standard with ACT'S G-Series quick exhaust valve permanently mounted. This patent pending valve was designed specifically for use with ACT Flash Cannon Air Cannon. It quickly evacuates air from the Air Cannon valve, guaranteeing a full, powerful blast even when the control valve is up to 100' from the Air Cannon. This unique valve also insures closure of the Air Cannon valve immediately after the blast. This feature of immediate valve closure, **without the use of a spring**, is unique to ACT Flash Cannon G400 Air Cannons. Other manufacturers use a spring which can break and cause down time.

Test Firing the Air Cannon:

Before mounting the Air Cannon to the discharge pipe for the first time (or before remounting after servicing the Air Cannon valve), do a test firing. During tests, place the Air Cannon on its side with the end **opposite** the discharge opening adequately supported to withstand the recoil that occurs when the Air Cannon is fired. The pressure relief valve must be in place.

WARNING

- ⇒ **Because of the hazards associated with the force of the blast and the recoil, do not fill the Air Cannon pressure vessel beyond 60 psi (4.0 bar) for testing purposes. Minimum pressure for testing is 45 psi (3 bar).**
- ⇒ **Warn Personnel in the testing area to stay way from the Air Cannon discharge outlet. The air blast can cause serious injury.**
- ⇒ **Wear eye and ear protection. Air Cannons produce a very loud noise when discharged in open space.**



G400 Series Air Cannons Installation and Operating Instructions



SECTION III - INSTALLATION

Preparation and Background:

Air Cannon Placement: To be sure Air Cannons provide the greatest effect, it is important to properly locate them on the storage structure. The placement and quantity of Air Cannons depends on several factors.

1. **Shape of the storage structure** - In general, square structures require more Air Cannons than round structures because materials tend to hang up in the corners. Be sure the Air Cannons will reach all major problem areas such as corners and the base of any known or suspected areas of bridging, arching, rat holing, or clinging (see page 1).
2. **The degree of material flow desired** - If Air Cannons are used to constantly move or aerate the material, or if the sides of the storage structure must be kept very clean, more Air Cannons will be needed than if they are only used to restore material flow after a stoppage.
3. **Properties of the bulk material** - Each Air Cannon has an approximate “area of influence” which varies with the properties of the bulk material. As a rule of thumb, for Air Cannon applications, bulk materials are grouped into the two categories below.

Type I Material

Stored in structure with low sloping walls
 Stored in structure with small discharge outlet
 Density in excess of 55 lb/ft³ (880 kg/m³)
 Clings, regardless of weight
 Compacts easily
 Greasy or pasty consistency
 “Sets up” or hardens during holding
 Large chunks or mixed size
 Heavily oil- or water-laden

Type II Material

Stored in structure with high sloping walls
 Stored in structure with large discharge outlet
 Density less than 55 lb/ft³ (880 kg/m³)
 Does not cling
 Spongy and does not compact
 Dry or powdery
 Flows easily under most conditions

NOTE

If your bulk material has *two or more* of the properties listed for Type I, consider it a *Type I Material*. If it has *none or only one* of the properties for Type I, but has several Type II properties, consider it a *Type II Material*.

Use the following charts and diagrams to assist in determining the number and placement of the Air Cannons. For best coverage, make sure the areas of influence of the Air Cannons overlap.

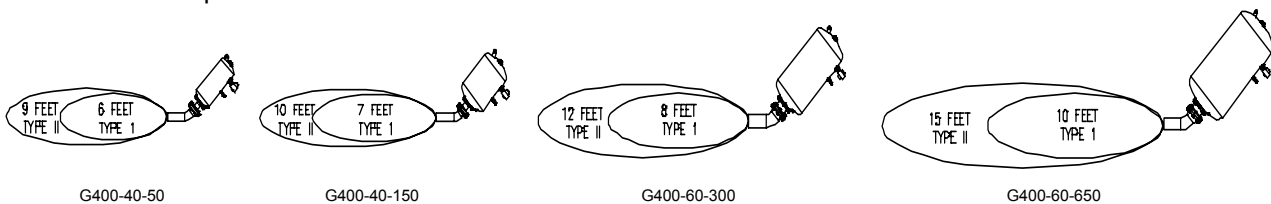



G400 Series Air Cannons Installation and Operating Instructions



AIR CANNON MODEL	MATERIAL TYPE	NUMBER OF AIR CANNONS RECOMMENDED PER BIN / HOPPER												AREA OF INFLUENCE			
		DIAMETER of STRUCTURE															
		FT	3	5	10	15	20	25	30	35	40	45	50	FT	M		
2.5" DISCHARGE:																	
GW2.5-8-24	I		1	3	6	9	12	15	18	21	24	27	30	4	1.2		
	II		1	2	3	5	6	7	8	10	12	13	15	7	2.1		
4.0" DISCHARGE:																	
GW4-12-28 G400-40-50	I		*	3	4	6	10	12	14	16	18	20	25	6	1.8		
	II		*	2	3	4	5	6	7	8	10	11	12	9	2.7		
GW4-20-30 G400-40-150	I		*	2	4	6	8	10	11	12	15	16	18	7	2.1		
	II		*	1	2	3	4	5	6	7	8	9	10	10	3.0		
6.0" DISCHARGE:																	
GW6-24-48 G400-60-300	I		*	2	3	5	6	8	9	10	12	14	16	8	2.4		
	II		*	1	2	3	4	5	6	7	8	9	10	12	3.7		
GW6-30-60 G400-60-650	I		*	1	2	3	4	5	7	10	10	11	12	10	3.0		
	II		*	1	1	2	2	2	2	3	4	5	5	16	4.9		

* This application is too small for this model Air Cannon.

NOTE

The above chart is provided as a guide for selection. The Area of Influence data is based on filling the Air Cannon at 90 psi (6.2 bar).

4. **Additional Guidelines** - If the discharge pipe will be longer than 6 feet (1.8 meters) in length, it is recommended that the next larger size Air Blaster be used.

Aiming the Air Blast: For Air Cannons to provide the greatest effect, it is important to aim them properly. Direct the blast at problem areas such as corners and the base of any known or suspected areas of bridging, arching, rat holing, or clinging. However, directing the blast straight out into the storage structure most often has disappointing results. A much more productive blast is one that skims the internal surface of the structure, forcing the problem material from the wall and allowing gravity to pull it down towards the storage vessel outlet. Therefore, where possible, direct the blast so it will parallel the inside wall, shearing material away from the wall to restore material flow. Since this is often difficult, Applied Conveyor Technology has developed its patented **Tan-gential Mount** system. With **Tangential Mounting** the Air Cannon discharge is directed down-ward at a steep angle and to the side. This achieves the following:

1. The "tangential" angling of the discharge (at least 60° below the perpendicular to the storage structure wall) helps the blast to skim material from the wall.
2. The downward orientation pushes the bulk material toward the storage structure outlet and also prevents loosened material from entering the discharge pipe and possibly contaminating the Air Cannon valve.
3. The sideward angling of the discharge (same direction for all Air Cannons on the structure) helps expand the area of influence around the circumference of the structure and promotes a "cyclone" motion of the material all in one rotary direction, further assisting in the flow of material.



G400 Series Air Cannons Installation and Operating Instructions



When using *tangential mounting*, overlap blast patterns to give the most effective coverage. Aim the first Air Cannon towards the outlet of the stor-age structure. Locate the next Air Cannon above the other and offset to the left, always keeping in mind the area of influence when firing down and to the right.

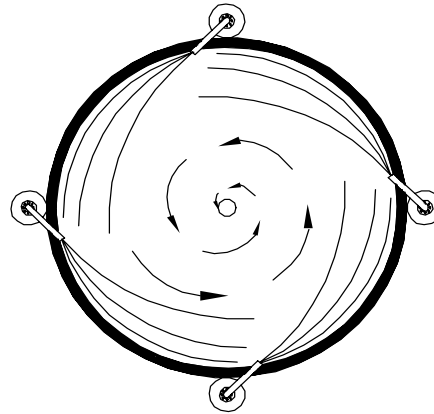

To assist with mounting and aiming of Air Cannons, Applied Conveyor Technology offers **Tangential Mount Discharge Assemblies**. These mount assemblies which can be welded or bolted to the storage structure direct the air blast down-ward (60° below the perpendicular to the wall) and 20° to the right (other configurations can be fabricated upon request). The discharge assembly supports the Air Cannon as well (as long as the structure wall has adequate thickness) and includes a mount flange for the Air Cannon and all hardware. Shown is a Tangential Mount Discharge Assembly with a 4" discharge. Also available for a 2.5" or 6" discharge. (Either a ring gasket or full-face gasket is supplied with discharge assembly.)

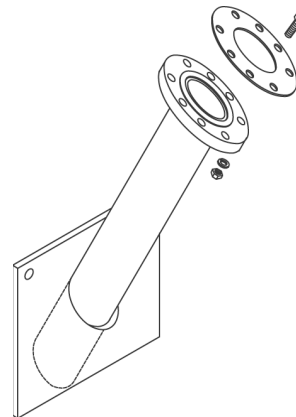

Below are some examples of Air Cannon system configurations using *Tangential Mounting*.

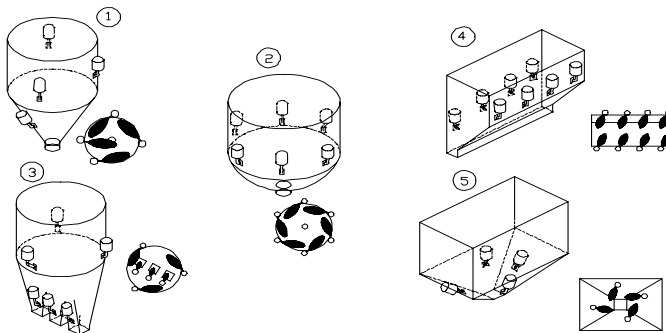

NOTE

High temperature nozzles, mount plates, and discharge assemblies are available from Applied Conveyor Technology. Installation instructions for these products are not included in this manual. If you have high temperature nozzles, mount plates, and/or discharge assemblies and need installation instructions, please contact Applied Conveyor Technology, Inc.

Air Cannon Orientation: In general, it is best to mount the Air Cannon so the discharge pipe is straight and as short as possible. This allows the maximum blast force to be applied to the material in the storage vessel. A downward slant to the discharge pipe helps prevent the stored material from contaminating the Air Cannon. However, due to space limitations, these guidelines cannot always be followed. Sometimes the discharge pipe will have to have a bend or be longer in length, and the Air Cannon may need to be oriented at different angles. If the air source is of poor quality, containing much water, or if condensation is a problem, the Air Cannon pressure vessel will need to be drained occasionally. To assist in draining the tank, three accessory ports are provided - one on the side of the tank, one on the end near the discharge, and one on the end near the air inlet. When mounting, be sure the Air Cannon is oriented so two of these ports are pointed downward. Once the Air Cannon is mounted, place a drain valve in the lowest of the three ports. One of the other accessory ports is used for the safety relief valve (provided with the Air Cannon). Air Cannons manufactured before May 2001 have only two accessory ports. They do not have the port on the end of the tank opposite the discharge pipe (next to current air inlet port).

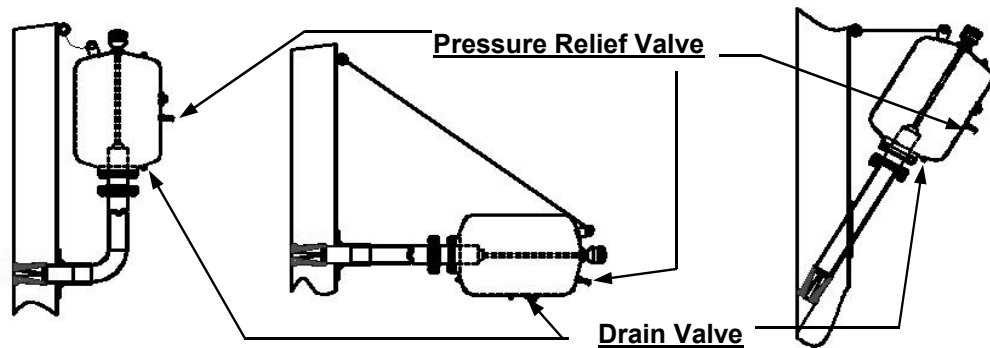

Required Storage Structure Wall Thickness: The storage structure wall must be rigid enough to support the weight of the Air Cannon and withstand the forces that occur during discharge. Reinforce structure walls less than 3/16" (5 mm) thick. Please see minimum thickness requirements below. **Tank Mount Hardware** is available from Applied Conveyor Technology to help support the weight of the Air Cannon and withstand the firing forces. Contact Applied Conveyor for mount hardware.

Air Cannon Model	Weight		Minimum Wall Thickness
	lbs	kg	
G400-40-50	94	43	3/16"
G400-40-150	128	58	1/4"
G400-60-300	260	118	1/4"
G400-60-650	554	251	1/4"

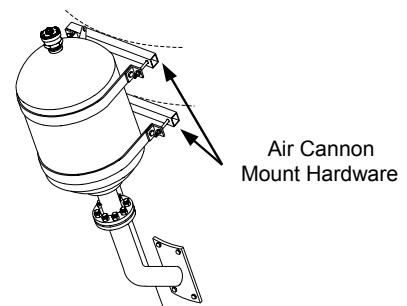

Air Cannon Plumbing: As described under "Required Accessories" (pages 6) there are a number of air control components necessary for full operation. To ensure safe operation and optimum performance of your Air Cannon system, install these air control components as shown in the plumbing diagrams in Appendix D.



G400 Series Air Cannons Installation and Operating Instructions



Visual Inspection: Please note the condition of the shipping container before opening. The shipping container will include the Air Cannon, pressure relief valve, operating instructions, and warranty card. Make sure all parts are located before discarding the container. Inspect the Air Cannon for any damage, such as dents, that might have occurred during shipment. Any Air Cannon accessories (valves, discharge assemblies, timers, etc.) ordered from ACT will be packaged separately. Please verify that all items ordered have been received. Contact ACT Customer Service or your distributor if there are any missing parts, apparent damage, or other irregularities. Report any damage to the delivery service. Complete any necessary claim forms.

Temporary Plug Removal: Tank openings are fitted with plastic plugs which are removed prior to attaching the air line, discharge pipe, or pressure relief valve. The small port at the end of the tank near the discharge opening has a steel plug. This is a permanent plug that should **not** be removed unless this port is needed for a drain valve or as an alternate location for the pressure relief valve.

WARNING

- ⇒ Before working on any storage structure, lock out / tag out any equipment that loads or unloads material from the structure.
- ⇒ If equipment will be installed in an enclosed area, test gas levels or dust content before using a cutting torch or welding equipment. Using a cutting torch or welding in an area with sufficient gas or dust levels can cause an explosion.

Installing Discharge Pipe:

The discharge assembly must be able to support the Air Cannon and direct the air blast towards the problem area.

Structure Wall Opening: Instructions for making the opening for the discharge pipe in the storage structure wall are not specific because of the wide variety of structures, wall materials, etc. Generally, the hole in the wall for the discharge pipe will be circular if the pipe is entering perpendicular to the wall or elliptical if using Applied Conveyor Technology's patented **Tangential Mounting**. The chart in Appendix G defines the height and width of the ellipse for each of the three discharge pipe sizes offered. These are for a 60° downward slope (from perpendicular to the wall surface) and a 20° rotation to the right.

IMPORTANT

- ⇒ For high temperature applications the discharge pipe must be long enough to ensure the Air Cannon piston is not exposed to temperatures exceeding 400°F (200°C). Exposure to temperatures greater than 400°F will cause the piston to seize. Damage caused by operating Flash Cannon G400 Air Cannons at temperatures in excess of 400°F are not covered by the warranty. See APPENDIX H for information on mounting G400 Air Cannons on high temperature applications (i.e. kilns with temperatures up to 2,000°F or 1,100°C).
- ⇒ Before cutting a hole in the structure wall, be sure there is adequate space to mount the Air Cannon to the discharge assembly.

Discharge Pipe Features: If not using a discharge assembly provided by ACT, please use the following guidelines in constructing a discharge pipe:

1. When used on kilns with temperatures of 2,000°F (1,100°C), the discharge pipe should be long enough to place the Air Cannon at least 36" from the kiln wall and contain at least one long radius bend.



G400 Series Air Cannons Installation and Operating Instructions



2. Use schedule 40 steel pipe or a higher grade for all high temperature applications.
3. Avoid sharp bends in the discharge pipe. For bends use a long radius elbow for a more effective blast.
4. If the pipe must be more than 6 feet (1.8 m) long consider using the next larger size Air Blaster.
5. When determining the pipe length keep in mind the length of pipe needed to give proper clearance for the Air Cannon tank to clear the structure wall, the thickness of the wall, and the amount of pipe that will be extending into the storage area.
6. The pipe should extend into storage area far enough to be cut at a 45° angle to form a "pocket" around the pipe end to prevent material from clogging it. (The approximate extension of the pipe depends on the model: G400-40 = 7", G400-60 = 10-10.5")
7. Use a standard slip-on pipe flange to mount the Air Cannon to the discharge pipe. Select the size (4.0", or 6.0") to match the pipe size and the mounting flange on the Air Cannon.

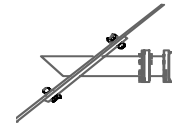

Installing the ACT Tangential Mount Discharge Assembly:

1. Determine the location of the Air Cannon discharge pipe. Be aware of structural obstacles which may interfere with mounting the Air Cannon to the mount flange on the end of the discharge pipe.
2. Using the Coordinates and Dimensions of Elliptical Openings in Appendix G, make a template of cardboard or other durable material. Enlarge the elliptical shape of the pattern by 1/2" (13mm) for ease of fitting during installation. The pattern may also be used to locate bolt holes if the mount plate is to be bolted to the structure wall.

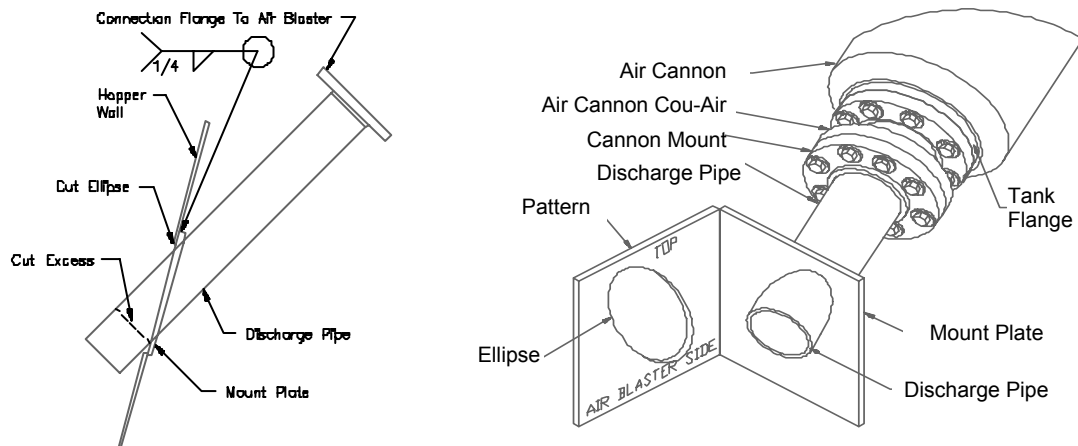

3. Use the pattern to mark the opening on the structure wall. When working from the outside of the structure, the long diameter of the elliptical shape should run from upper left to lower right (unless you have ordered a special configuration).
4. Cut the hole in the structure wall.
5. Fit the discharge pipe into the wall so the mount plate is flush with the outer wall surface. Evaluate the amount of pipe extending into the storage chamber. Cut the pipe using a square cut (perpendicular to the length of the pipe) so the lower edge is flush with the inside of the structure wall. The upper edge will protrude into the flow area slightly.
6. Be sure the discharge assembly is in place with the mount plate flush with the outer wall surface. Seal weld the mount plate to the wall.



G400 Series Air Cannons Installation and Operating Instructions



NOTE

If the storage structure wall is too curved and leaves an excessive gap for welding, trim the mount plate with a torch to the required size to reduce the gap as shown below. Do not trim the mount plate closer than 2" (50 mm) from the discharge pipe. The remaining pipe must overlap the mounting surface by at least 1/2" (12 mm). After trimming the mount plate, reposition the discharge assembly in the structure wall and seal weld the mount plate to the outer wall surface.

NOTE

If the discharge assembly will be bolted to the structure wall, use at least four (4) 5/8" (16mm) bolts to secure the mount plate. Drill holes in mount plate at least 1-1/2" in from each corner. Anchor bolts must extend at least 3" into the concrete wall. Otherwise the bolts should extend through the wall and be secured with lockwashers and nuts. Use gasket material between the mount plate and structure wall or apply sealant to the mount plate-wall joint to prevent air or material leakage.

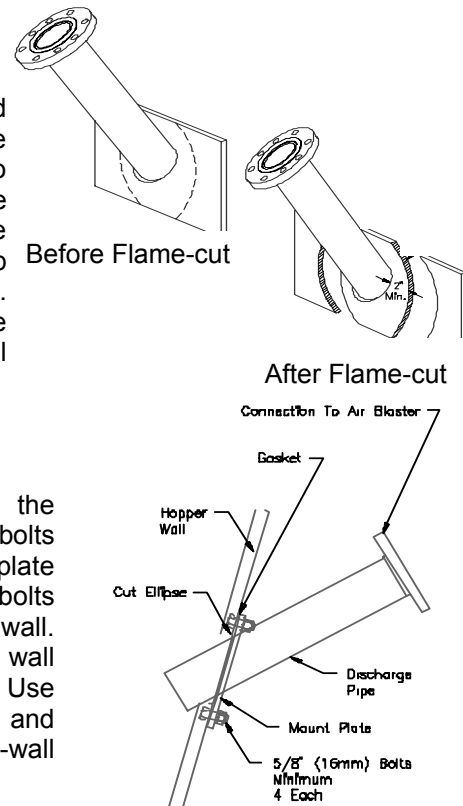

Mounting the Air Cannon to the Discharge Pipe:

The Air Cannon coupling flange is connected to a discharge pipe equipped with a mount flange. Be sure to rotate the Air Cannon to place the small ports facing downward (in case they will be needed to drain the Air Cannon tank at a future time).

WARNING

⇒ **The discharge pipe must be securely mounted to the storage structure wall. If any doubt about the rigidity of the mount exists, Applied Conveyor Technology strongly recommends using additional mount hardware to secure the Air Cannon. Contact Applied Conveyor Technology.**

1. Secure the Air Cannon coupling flange to the mounting flange on the discharge assembly using a gasket (either full-face or ring gasket) and the Grade 5 bolts, nuts, and washers provided. Use bolts no smaller than 1/8" (3 mm) less than the coupling bolt hole diameter. The bolts are tightened in three stages in a criss-cross pattern to ensure even tightening.
2. Be sure to install a safety cable to keep the Air Blaster from falling should it break loose from its mount. Use the ring on the end of the tank for this purpose. Securely attach the other end of the safety cable to a structural member.

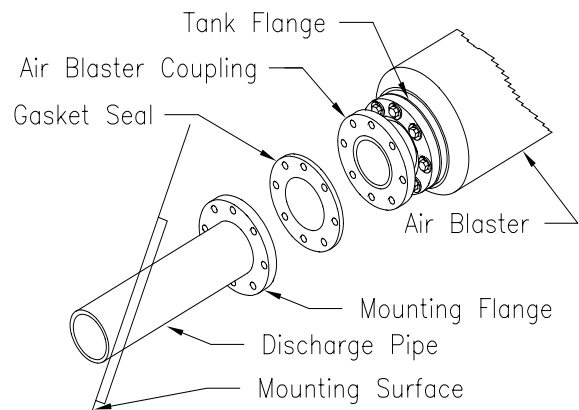



G400 Series Air Cannons Installation and Operating Instructions



WARNING

- ⇒ If the Air Cannon is mounted more than 6" (152 mm) above the ground, secure the Air Cannon to a structural member with a safety cable to prevent the Air Cannon from falling and causing serious injury if it came loose from its mount.

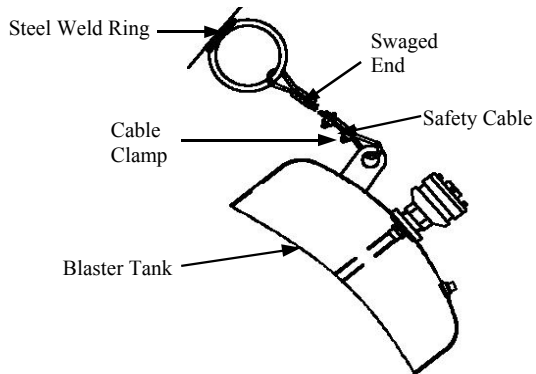

If a safety cable kit has been purchased from Applied Conveyor Technology, attach one end of the ca-ble to the steel ring with the provided clamp. The steel ring can be welded to or looped around a structural support. Using the other clamp, attach the other end of the cable to the safety tab on the end of the Air Cannon tank. Adjust the length of the cable to provide some slack. It should be short enough, however, to stop the Air Cannon from falling and hitting a person.

3. If a drain valve (not supplied) is to be used, install it in the lowest of the three small accessory ports (The tank should be mounted so two of these ports point down). Install the pressure relief valve (safety valve) in the side accessory port, or if that one has been used for a drain valve, in the unused port on either end of the tank (will have to remove the steel plug).

IMPORTANT

- ⇒ **Be sure to apply Teflon® tape to all threads before installing.**

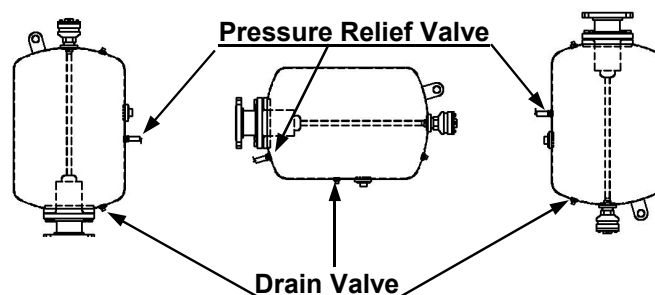

General Piping Instructions for Air Cannon System Air Control Components:

To ensure safe operation and optimum performance of your Air Cannon system, install necessary air control components as shown in the plumbing diagrams in Appendix D.

1. G400 Series Air Cannons come standard with ACT's Flash Cannon G-Series quick exhaust valve permanently mounted. This patent pending valve was designed specifically for use with ACT Flash Cannons. It quickly evacuates air from the Air Cannon valve, guaranteeing a full, powerful blast even when the control valve is up to 100' from the Air Cannon. The distance between the other components is not important. Only the sequence of the components along the air supply line is important.



G400 Series Air Cannons Installation and Operating Instructions



- Do not connect more than four Air Cannons to a single Filter-Regulator-Gauge / Shut-off Valve pair.
- The air supply lines required for plumbing Air Cannons and control components must be rated for a minimum of 150 psi (10.3 bar). Use 3/4" lines or greater between the 3-way control valve (manual or solenoid) and the Air Cannon or Quick Exhaust Valve. 1/2" lines or greater can be used everywhere else (between the control valve and the plant air source). If a timer is used to control Air Cannon firing sequence and time delay between blasts, wire each solenoid valve to the appropriate timer terminals. Wiring must adhere to all appropriate electrical standards.

Using Quick Exhaust Valve

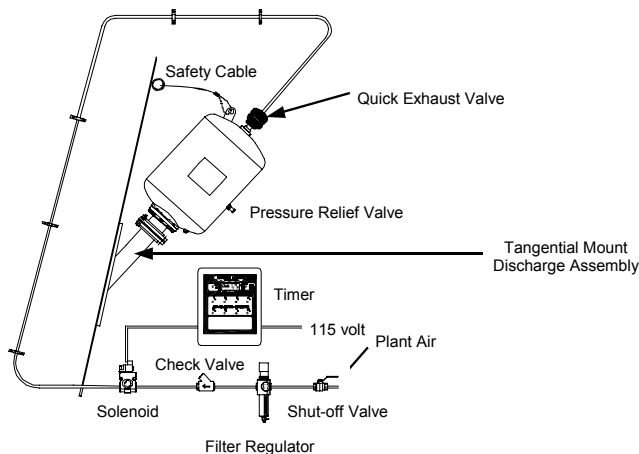

Air Cannon Control Component Installation:

Install each control component using Teflon® tape on all threaded connections.



⇒ **Be sure all connections are air tight. Any leak along the Air Cannon air supply line may cause the Air Cannon to discharge unexpectedly causing injury.**

- Shut-off Ball Valve Installation:** The 2-way shut-off ball valve is used to isolate the Air Cannon system from the plant air supply. A 1/2" valve is recommended. Locate it between the plant air supply and all other components in the Air Cannon system. Each shut-off valve should control no more than four Air Cannons. **Be sure to clearly label the shut-off valve and place it where it can be quickly and easily reached in an emergency or for routine maintenance.**

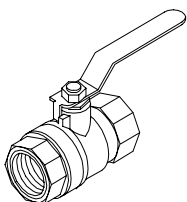

Shut-off Ball Valve

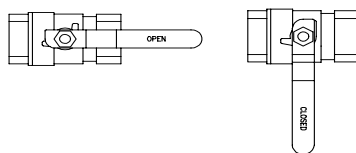

Filter-Regulator-Gauge

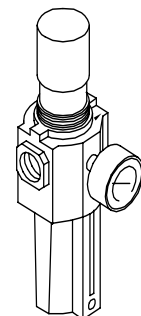

- Filter-Regulator-Gauge:** Install the filter-regulator-gauge (FRG) in the air supply line between the shut-off ball valve and the check valve. The FRG is designed to prevent



G400 Series Air Cannons Installation and Operating Instructions



damage to the Air Cannon and control components by filtering water and particulate contaminants from the air supply. A 1/2" FRG is recommended. Place the FRG where the filter reservoir can be drained daily (unless an auto-drain model is used). The FRG has an arrow cast in the housing, which indicates the required direction of air flow. It will not function if it is installed in the reverse direction. After installation set the air pressure to the Air Cannon between 80 and 100 psi (5.4 and 6.8 bar) for most applications (If using a solenoid valve in the system, the pressure should not be set at or below 40 psi).

3. **Check Valve Installation:** The check valve prevents accidental firing of the Air Cannon if an unexpected decrease in line air pressure occurs. If the pressure drops in the air supply, the check valve maintains pressure to the Air Cannon by preventing the backward flow of air. Install the check valve in the air supply line between the FRG and the 3-way control valve (manual or solenoid). A 1/2" valve is recommended. Be sure to install the valve with the cast-in arrow pointing in the direction of the air flow. If used in a horizontal line, be sure the hex head plug is on top, so the check valve will close properly. In a vertical line, the air flow must be upward in the line.

WARNING

- ⇒ Do not install in a vertical line where the air flow is downward, because the check valve will not close properly.
- ⇒ Do not install with the hex head plug on the bottom or pointing downward, because the check valve will not close properly.

Check Valve in Proper Orientation

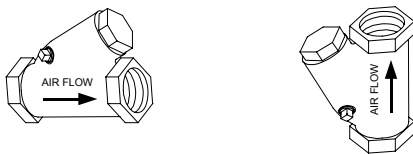

Check Valve in Improper Orientation

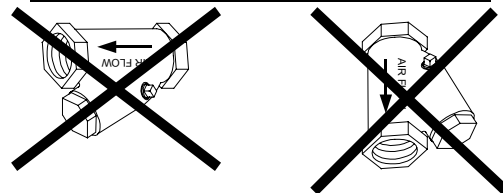

4. **3-Way Normally Open Valve Installation:** This valve controls the operation of the Air Cannon. Use either a manual valve for manual control or a solenoid valve for remote or automatic control. The solenoid valve is wired to either a remote manually triggered momentary switch or a micro-controller based sequencing timer such as ACT's *BLASTER MASTER* timer. Be sure the controller output is compatible with the electrical requirements of the solenoid valve. Follow all applicable local wiring codes.

Manual 3-Way Valve

Handle in 'Fill' Position

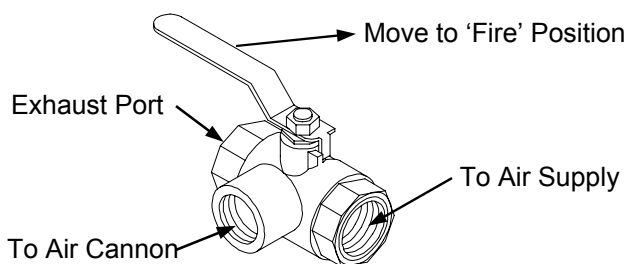

3/4" 3-Way N/O Solenoid Valve

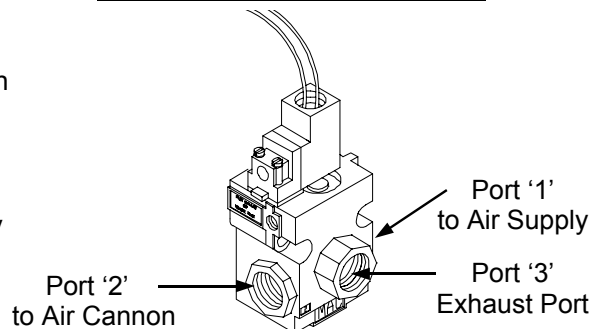

The valve is installed in the air supply line between the check valve and the Air Cannon.



G400 Series Air Cannons Installation and Operating Instructions



Since Flash Cannon G400 Series Air Cannons come standard with an ACT G-Series Quick Exhaust Valve, in-stall a 3/4" 3-Way Control Valve **within 100 feet** (30 meters) of the Air Cannon (all models). If a solenoid is used, be sure it is set in the normally open position ('3-NO' is indicated on the small white tab visible from the top). Use a 3/4" x 1/2" bushing to connect the 1/2" air supply line to the valve air inlet port (Solenoid port labeled '1'). The 3/4" line connecting the Solenoid to the Air Cannon quick exhaust valve is connected to the valve outlet (Solenoid port labeled '2').

Air Cannon Model	3-Way Valve Size	Solenoid Inlet Port Label	Inlet Bushing Size	Solenoid Outlet Port Label	Pipe Nipple Size for AB Tank Mounting	Air Line Size for Remote Mount < 10'
G400-40-50	3/4"	1	3/4" x 1/2"	2	3/4" x close	3/4"
G400-40-150	3/4"	1	3/4" x 1/2"	2	3/4" x close	3/4"
G400-60-300	3/4"	1	3/4" x 1/2"	2	3/4" x close	3/4"
G400-60-650	3/4"	1	3/4" x 1/2"	2	3/4" x close	3/4"

Contamination Protection: Connect a street elbow to the valve exhaust port. Position the elbow to point downward and add a 3" long nipple for exhaust extension. Refer to the table below for the appropriate size fittings to be used. The elbow with extension will keep contaminants from entering the valve through the exhaust port. Using a muffler to protect the exhaust port is **not** recommended, because it will reduce Air Blaster performance by significantly impeding the exhaust air flow.

Solenoid Valve Size	Exhaust Port Label	Street Elbow Size	3" Nipple Size
3/4"	3	3/4"	3/4"

IMPORTANT

- ⇒ **Be sure to test the solenoid valve before applying air pressure.**
 - ⇒ **The solenoid valve may not operate if the inlet pressure is less than 40 psi (2.75 bar).**
5. **Quick Exhaust Valve Installation:** G400 Series Air Cannon come standard with an Applied Conveyor Technology G-Series Quick Exhaust Valve permanently mounted. This patent pending valve was designed specifically for use with ACT Air Cannon. It quickly evacuates air from the Air Blaster valve, guaranteeing a full, powerful blast even when the control valve is up to 100' from the Air Blaster. This unique valve also insures closure of the Air Blaster valve immediately after the blast. This feature of immediate valve closure, **without the use of a spring**, is unique to ACT Flash Cannon G400 Air Cannons. Other manufacturers use a spring which can break and cause down time. The 3/4" air supply line from the 3-way normally open valve is connected at the QEV inlet port.



G400 Series Air Cannons Installation and Operating Instructions



1" G-Series Quick Exhaust Valve

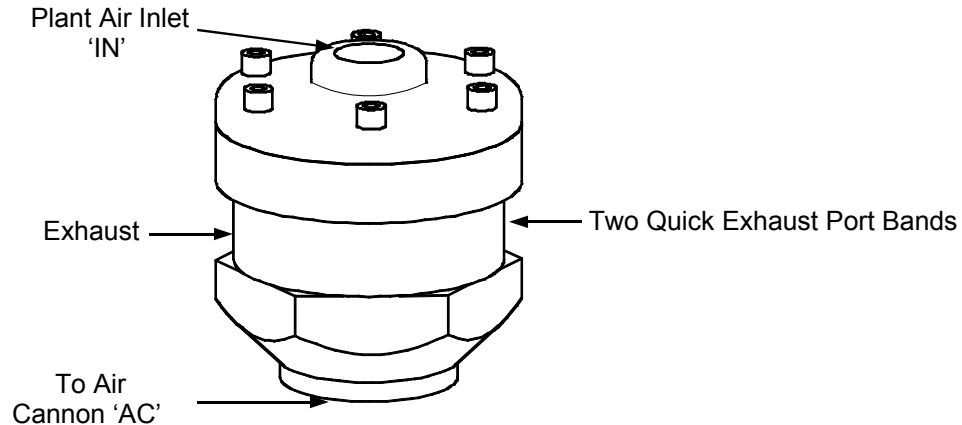

IMPORTANT

- ⇒ The G-Series Quick Exhaust Valve is fitted with two exhaust port bands. If “Replace Bands Now!” is visible, the outer band is missing and should be replaced immediately.

SECTION IV - AIR CANNON START-UP PROCEDURES

1. Make sure **all connections** for Air Cannons, discharge assemblies, and air & electrical components are secure.
2. Check all 3-Way Control Valves to ensure they are in the open position.
3. Set Filter-Regulator-Gauge (FRG) to minimum pressure position.
4. Open the Shut-off Ball Valve to allow plant air to enter the system.
5. Set the FRG to the pressure desired for charging the Air Cannons: **Minimum pressure = 40 psi**. Solenoid valves might not operate consistently at lower pressures. **Maximum pressure = 125 psi**. The Air Cannon tank is rated for 125 psi. Its safety relief valve will release and depressurize the tank if the pressure exceeds 125 psi. Pressure between 80 and 100 psi will give excellent performance for most applications.
6. Check all airline pipe connections for leaks. Mark all leaks found and de-pressurize the system by closing the Shut-off Ball Valve.
7. Repair any leaks found in Step 6 and return to Step 3. If no leaks were found, continue with Step 8.
8. Test each Air Cannon separately. For **manual control valves**, simply move the lever to the closed position to fire the Air Cannon. Return the lever to the open position to refill the Air Cannon. If **sole-noid control valves** are used, activate the solenoid by pressing the remote switch or by pressing the appropriate timer switch while the timer is in **manual mode**. Refer to the **Troubleshooting Guide** in Appendix A if the Air Cannon does not fire or has inadequate force.
9. If the Air Cannon System is to be controlled by a micro-controller based sequencing timer, such as the ACT **Blaster Master** timer, refer to the timer instruction manual to configure the timer for Air Blaster firing sequence, time between blasts, and time between cycles. Test the timer configuration and adjust as necessary to obtain the desired results.
10. After satisfactory completion of the above Steps, your Applied Conveyor Technology Flash Cannon Air Cannon system is ready for use.



G400 Series Air Cannons Installation and Operating Instructions



SECTION V - MAINTENANCE

Preventive maintenance is important to ensure effective and safe performance of the Air Cannon system.

Lubrication: ACT Flash Cannons require no lubrication.

Air Control Accessories: Check periodically to make sure all valves are clean and functional. The reservoir on the Filter-Regulator-Gauge should be drained daily. Clean unit and filter with warm water and mild soap as needed. Blow with compressed air to dry. Use a 40 micron filter when the filter element needs replacing.

IMPORTANT

⇒ **G-Series Quick Exhaust Valve:** Replace the exhaust port bands every 50,000 blasts or once per year. There should always be two bands in place. If "Replace Bands Now!" is visible, the outer band is missing and should be replaced immediately (see instructions below).

Air Blaster Mounting: All mounts must remain rigid. Check periodically and retighten as necessary. Any damaged or rusted parts should be repaired or replaced.

Air Cannon Internal Valve: The Air Cannon valve is designed to provide many years of maintenance free operation. Should the Air Cannon malfunction or performance appear to decrease, the internal valve should be inspected for wear or contamination. If the Air Cannon is used in a harsh environment, several Air Cannon in the system should be inspected periodically - semi-annually or annually - during routine plant maintenance periods. This rotating inspection schedule should indicate if the Air Blasters are showing any signs of wear or contamination that will need attention. Follow the instructions in section VI **Disassembly and Assembly of the Air Cannon**.

Spare Parts Recommendations: See Air Cannon System Recommendations in Appendix B. If the Air Cannon is not used in a harsh environment, an inventory of spare parts may not be needed.

SECTION VI - DISASSEMBLY AND ASSEMBLY OF THE AIR CANNON

Replacing the Quick Exhaust Valve Exhaust Port Bands: Replace annually or every 50,000 blasts.

WARNING

⇒ **The Air Cannon is fired by a sudden pressure drop in the air inlet line, therefore, all pressure within the tank must be relieved before the Air Cannon is serviced. Failure to relieve air pressure may result in unexpected Air Cannon discharge, causing serious injury or death to nearby persons.**

1. Turn off the air supply to the Air Cannon using the shut off ball valve.
2. Fire the Air Cannon to relieve all the pressure within the tank. Pull and hold the ring on the pressure relief valve mounted on the Air Cannon tank until **all** air has escaped from the tank.
3. Disconnect the air line from the Quick Exhaust Valve air inlet port.
4. Remove old bands by stretching and pulling them over the valve housing.
4. Install new bands one at a time. Stretch and slide each band over the housing until it lays flat over the recess around the exhaust ports. **Put the band with the printing, "Replace Bands Now!" on first with the printing facing outward.** The second band is then installed over the first to cover the printing.
5. Re-install the air line and recharge the Air Cannon by turning on the air supply using the ball valve.



G400 Series Air Cannons Installation and Operating Instructions



Dismounting the Air Cannon:

Tools Required: Two (2) each socket or box wrench, 500 lb (230 kg) capacity hoist.

WARNING

⇒ **The Air Cannon is fired by a sudden pressure drop in the air inlet line, therefore, all pressure within the tank must be relieved before the tank can be dismantled. Failure to relieve air pressure may result in unexpected Air Cannon discharge, causing serious injury or death to nearby persons.**

1. Turn off the air supply to the Air Cannon using the shut off ball valve.
2. Fire the Air Cannon to relieve all the pressure within the tank. If it is not possible to fire the Air Cannon, pull the ring on the pressure relief valve mounted on the Air Cannon tank.
3. Remove the pressure relief valve from the Air Cannon.
4. ~~Disconnect~~ Disconnect the air line from the Quick Exhaust Valve air
5. Loosen the mounting bolts connecting the Air Cannon coupling to the discharge pipe. Be sure **not** to loosen the bolts connecting the coupling to the Air Cannon tank.
6. Using the hoist, support the Air Cannon by the ring on the end of the tank. Remove the safety cable.
7. Remove the mounting bolts previously loosened and lift the Air Cannon clear of the discharge pipe. If the gasket is damaged, discard it and use a new gasket of the same type when remounting the Air Cannon. If the gasket is in good condition, it can be reused when remounting the Air Cannon.
7. Lower the Air Cannon to the ground and transport it to an appropriate working area.

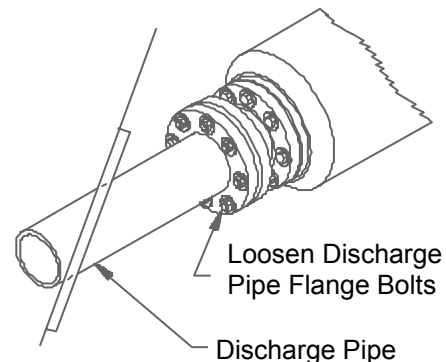
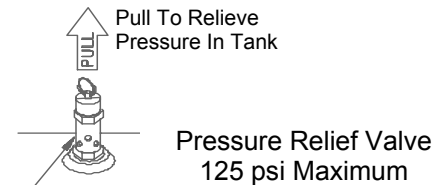

Removing the Internal Valve:

Tools Required: Two (2) each socket or box end wrench, 24" pipe wrench, and large adjustable wrench.

Refer to the Air Cannon parts list in [Appendix F](#).

1. The G-Series Quick Exhaust Valve does not have to be removed to access the internal valve.

NOTE

The internal fill line does not have to be removed to access the internal valve. If no problems are suspected with the internal fill line, skip step #2 and proceed to #3.

2. Use the adjustable wrench to loosen the G-Series Quick Exhaust Valve. Remove the valve and the connected internal fill line from the tank as a single unit.



G400 Series Air Cannons Installation and Operating Instructions



IMPORTANT

Do not remove the fill line from the Quick Exhaust Valve.

Check the end of the fill line for damage or burns. Check the fill line for cracks or other damage.

3. Remove the bolts that fasten the coupling to the tank flange. Remove the coupling and the gasket from the Air Cannon. If the gasket is damaged, discard it and use a new gasket of the same type when assembling the Air Cannon. If the gasket is in good condition, it can be reused.
4. Push the valve piston back and insert fingers into the valve body. Carefully pull the valve body from the tank.
5. Inspect the inside of the Air Cannon tank for corrosion and contamination. Clean the inside of the tank with compressed air prior to reassembly.

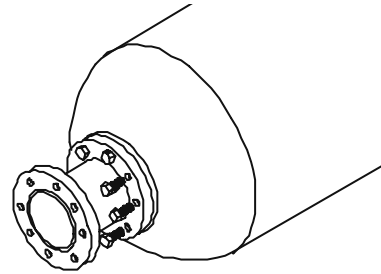

Valve Disassembly:

Tools Required: Arbor press, large retaining ring pliers, and a small flat blade screw driver. (A soft wooden block and hammer may be used in place of the Arbor press).

1. Use the large retaining ring pliers to remove the retaining ring at the base of the valve cap.

WARNING

- ⇒ **The retaining ring is under high tension. Use care to ensure the ring does not fly off the pliers or out of the valve body and injure nearby persons.**
2. Inspect the retaining ring and retaining ring groove for wear or damage. Replace retaining ring or valve body if damage is evident.
 3. Using the arbor press, carefully remove the piston, and valve cap from the valve body. Light pressure on the face of the piston may be necessary.
 4. After the piston and valve cap are removed, press the valve seat from the valve body.
 5. Use the flat blade screw driver to carefully pry the o-rings from the valve seat, piston and valve cap.

Valve Inspection:

1. Clean all valve parts thoroughly in a non-solvent based cleaner.
2. Inspect the valve body bore for deep scratches, pits, grooves, or corrosion. The valve body bore must be in good condition to function properly.
3. Inspect the sealing face of the valve seat for smoothness. The valve seat must be smooth to properly seat the piston.
4. Check the piston face, sealing bevel, and o-rings for heat damage, chemical erosion, or signs of wear. The piston must be in good condition with smooth sealing and wear surfaces. Minor pitting in the nose of the piston is acceptable if the pits are less than 1/16" (2 mm) deep and the sealing bevel is not pitted. Any distortion of the piston which hampers smooth sliding or exhibits excessive clearance in the valve body is unacceptable.



G400 Series Air Cannons Installation and Operating Instructions



- It is recommended that, once removed, all o-rings on the piston, valve seat, and valve cap be replaced with type meeting manufacturer's specifications.

Assembling the Valve:

- Replace the o-rings on the valve seat, valve cap, and piston. The piston uses a "floating" type o-ring fit, therefore the piston o-ring will not fit tightly in its groove. Sparingly coat all o-rings (**except the o-ring on the cap that serves as the check valve**) with silicone lubricant/grease. Be careful not to damage the o-rings.
- Assembly of the Air Cannon valve proceeds in the reverse order of disassembly except all parts are **individually** pressed into the valve body. **Do not press all parts in at the same time.** Using the press, position the valve seat (bevel side up) completely down into the valve body. The beveled side of the seat should match the beveled face of the piston. Take care that the o-ring is not cut as it passes over the window openings in the valve body.
- Lightly oil the sides of the piston and the bore (internal surface of the valve body). Align the o-ring in the groove on the side of the piston.
- Making sure the piston remains straight, push the piston (bevel face down) and o-ring into the valve body until the o-ring approaches the valve cap seat (shoulder machined inside valve body at top of piston bore).
- Because of the floating o-ring fit, the o-ring may bind as it tries to pass over the valve cap seat, preventing the piston from sliding smoothly into the bore. While using only hand pressure on the piston, use a thin piece of metal or screw driver to work the o-ring into the piston groove, allowing the piston to slide completely into the bore.

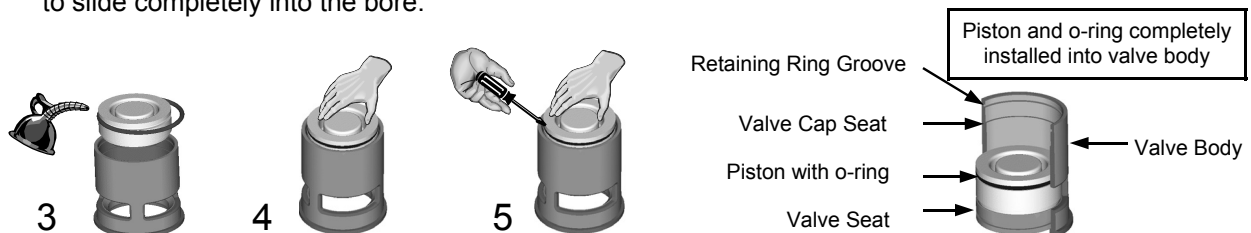

- Press the valve cap into the valve body until it reaches the valve cap seat. The retaining ring groove will be visible above the cap.
- Install the retaining ring using the retaining ring pliers. The retaining ring will have a sharp edge and a rounded edge. Check the sharp edge of the retaining ring for burrs or rounded areas. Install the retaining ring with the **sharp edge away from the valve cap**. Check that the retaining ring is properly seated in the valve body groove.
- Check the piston to make sure it slides easily within the valve body.
- Check the o-ring check valve on the valve cap to see that it is properly seated in its groove.

Assembling the Air Cannon:

- If the internal fill line was removed, check to see that the end is smooth, burr free, and slightly beveled, so it will slide easily into the seal in the valve cap inlet port. Install the internal fill line into the tank. **Be sure to use Teflon® tape on the Quick Exhaust Valve threads.**



G400 Series Air Cannons Installation and Operating Instructions



2. Examine the end of the internal fill line from the tank discharge opening. The fill line must be centered within the tank opening. If it is not centered, use a rod slipped into the end of the fill line to bend the tube so it appears centered.
3. Apply a small amount of silicone grease to the end of the fill line prior to installing the valve assembly.
4. Install the valve assembly in the tank opening, taking care to slide the inlet port on the valve cap over the end of the fill line. When contact is made between the fill line and the o-ring seal in the cap inlet port, twist and slightly rock the valve until the valve slips fully into the recess in the tank flange.
5. Inspect and install the flange coupling. Be sure to use a new gasket, if necessary, between the Air Cannon tank flange and the coupling flange. The gasket should meet manufacturer's specifications. No adhesive is required.

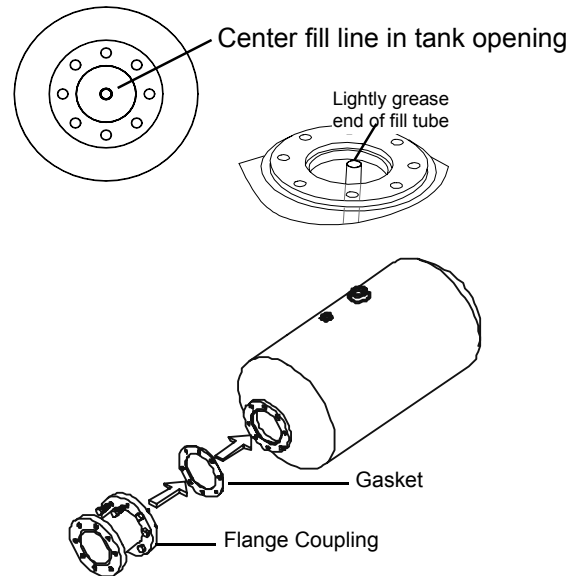

Testing the Air Cannon:

After assembly and before mounting the Air Cannon on the discharge pipe, test the Air Cannon.

WARNING

- ⇒ **Use eye and ear protection when testing the Air Cannon.**
 - ⇒ **Warn all personnel in the testing area to stay clear of the discharge outlet.**
 - ⇒ **Be sure no objects within 25 feet are in the path of the air blast.**
1. Clamp or wedge the Air Cannon in place on the floor so that it cannot move from the recoil when fired.
 2. Install the pressure relief valve in the Air Cannon tank. Be sure to use pipe thread sealant.
 3. Attach a quick disconnect on the Quick Exhaust Valve air inlet port.
 4. Attach an air hose to the quick disconnect and fill the tank to about 40 psi (2.8 bar).
 5. Remove the air hose to discharge the Air Cannon.

Mounting the Air Cannon:

To mount the Air canon follow the installation instructions starting on page 13.



G400 Series Air Cannons Installation and Operating Instructions



APPENDIX A - TROUBLESHOOTING

Prior to shipment, all ACT Flash Cannons are tested for pressure and function according to corresponding pressure vessel regulations and quality manufacturing specifications. Despite the simple and sturdy construction, malfunctions can occur due to the kind of application, installation, and/or operation. The following list should help identify the causes of some problems that occur and gives possible solutions to eliminate those problems. Control Valve = 3-Way N/O Manual or Solenoid Valve. Operating Valve = Quick Exhaust Valve.

PROBLEM	PROBABLE CAUSE	SOLUTION
Air Cannon discharges with weak or no blast.	Air leakage in control valve or operating exhaust valve.	Check control valve and operating valve for wear, damage, contamination. Check system for leaks.
	Control or operating valve is malfunctioning.	Check air filtering system. Clean or repair valves as needed.
	Control valve is too far from the Air Cannon, or the size of the valve is too small.	Control valve must be within 10 feet of the Air Cannon. If distance is greater, install a Quick Exhaust Valve at the Air Cannon. Be sure valves are the recommended size.
	Piston lodged in valve due to contamination.	Disassemble and clean valve assembly. Check filter element.
	Low Air Pressure.	Check pressure at Air Cannon and increase regulator setting. Use a larger diameter fill line.
	Air Cannon not completely filled before it is discharged.	With manual firing give the Air Cannon more time to fill. Increase the between blast time on the timer. Use a larger diameter fill line.
	Sharp bends in the discharge pipe reduce force output.	Use long radius elbows.
	Discharge pipe is blocked with material.	Clean pipe and reposition it to prevent material from entering.
	Piston seized in valve due to temperatures exceeding 400°F.	Lengthen the discharge pipe & add a long radius bend to reduce temperatures seen by the piston.
	Piston is not sealing.	Clean or replace piston and o-rings. Check valve seat for dents, nicks, etc. The piston and valve seat must seal.
	Pressure vessel is punctured or cracked.	Replace pressure vessel.
Air Cannon is firing into an area void of material.	Air Cannon discharge should be above the blockage of material to blast through the blockage.	



G400 Series Air Cannons Installation and Operating Instructions



APPENDIX B - SYSTEM RECOMMENDATIONS

G400-Series Air Cannons (For Ambient Temperatures < 400°F.)

FLASH CANNON MODEL		G400-40-50	G400-40-150	G400-60-300	G400-60-650
Part Number		#814100	#814300	#817400	#817500
Discharge Size - Inches (Millimeters)		4.0 (102)	4.0 (102)	6.0 (152)	6.0 (152)
Tank Size - Inches (Millimeters)		12x28 (305x711)	20x30 (508x762)	24x48 (610x1219)	30x60 (762x1524)
Tank Volume - Cubic Feet (Liters)		1.7 (49)	5.0 (142)	10.6 (299)	22.8 (645)
Mount & Straight Discharge Assembly - Weld on	1 / Air Cannon	4HTW	4HTW	6HTW	6HTW
Part Number		#850040	#850040	#850060	#850060
Discharge Size - Inches (Millimeters)		4.0 (102)	4.0 (102)	6.0 (152)	6.0 (152)
High Temperature Diffusion Nozzle	Straight	#860040	#860040	Contact ACT	
Rated for 1650-2100°F. (900-1150°C.)	Adjustable Angle	#860049	#860049	Contact ACT	
Safety Cable Kit	1 / Air Cannon	#169014	#169014	#169014	#169014
Timer - Master Blaster TMB-108 - 110V	1 / 8 Air Cannon	#891008	#891008	#891008	#891008
Number of Air Cannon Circuits		8	8	8	8
Maximum Number of Cannons per		24	24	24	24
Quick Exhaust Valve - Factory Mounted	Included	Standard on all G400 Air Cannons			
Inlet Port Size - Inches NPT		3/4	3/4	3/4	3/4
3-Way Normally Open Solenoid Valve	1 / Air Cannon	#456112	#456112	#456112	#456112
Port Size - Inches NPT		3/4	3/4	3/4	3/4
Airline Check Valve	1 / Air Cannon	#290208	#290208	#290208	#290208
Port Size - Inches NPT		1/2	1/2	1/2	1/2
Filter/Regulator w/ Gauge	1 / 4 Air Cannon	#270808	#270808	#270808	#270808
Port Size - Inches NPT		1/2	1/2	1/2	1/2
2-Way Shut Off Valve	1 / 4 Air Cannon	#290108	#290108	#290108	#290108
Port Size - Inches NPT		1/2	1/2	1/2	1/2
Fittings:					
Bushing-Connect Solenoid to 1/2" airline	1 / Air Cannon	#295412	#295412	#295412	#295412
Port Size - Inches NPT		3/4x1/2	3/4x1/2	3/4x1/2	3/4x1/2
Street Elbow-Protect Solenoid Exhaust	1 / Air Cannon	#293412	#293412	#293412	#293412
Port Size - Inches NPT		3/4	3/4	3/4	3/4
3" Nipple - Solenoid Exhaust Extension	1 / Air Cannon	#294612	#294612	#294612	#294612
Size - Inches NPT		3/4	3/4	3/4	3/4



G400 Series Air Cannons Installation and Operating Instructions



System Substitutions

G400 Series Air Cannon

SUBSTITUTIONS:	G400-40-50	G400-40-150	G400-60-300	G400-60-650
1) A Filter/Regulator with Gauge & AUTODRAIN can be provided in place of the standard model. With the standard FRG, the bowl must be drained on a regular basis to maintain optimum performance. Substitute for the standard Filter/Regulator w/ Gauge above Port Size - Inches NPT	#270908 1/2	#270908 1/2	#270908 1/2	#270908 1/2
2) Get 4" discharge on GW6 Models. Substitute for Air Cannon Substitute for Discharge Assembly Straight High Temperature Diffusion Nozzle Adjustable Angle High Temperature Diffusion Nozzle	N/A N/A N/A N/A	N/A N/A N/A N/A	#817420 #850040 #860040 #860049	#817520 #850040 #860040 #860049
3) Get 90 degree Discharge Assembly. Substitute for Straight Assembly	#854042	#854043	Contact ACT	
4) 220 Volt Timer available but will also require 220 Volt Solenoids. 220 Volt TMB-108 Timer 220 Volt 3-Way N/O Solenoid Valve	#892008 #457012	#892008 #457012	#892008 #457012	#892008 #457012

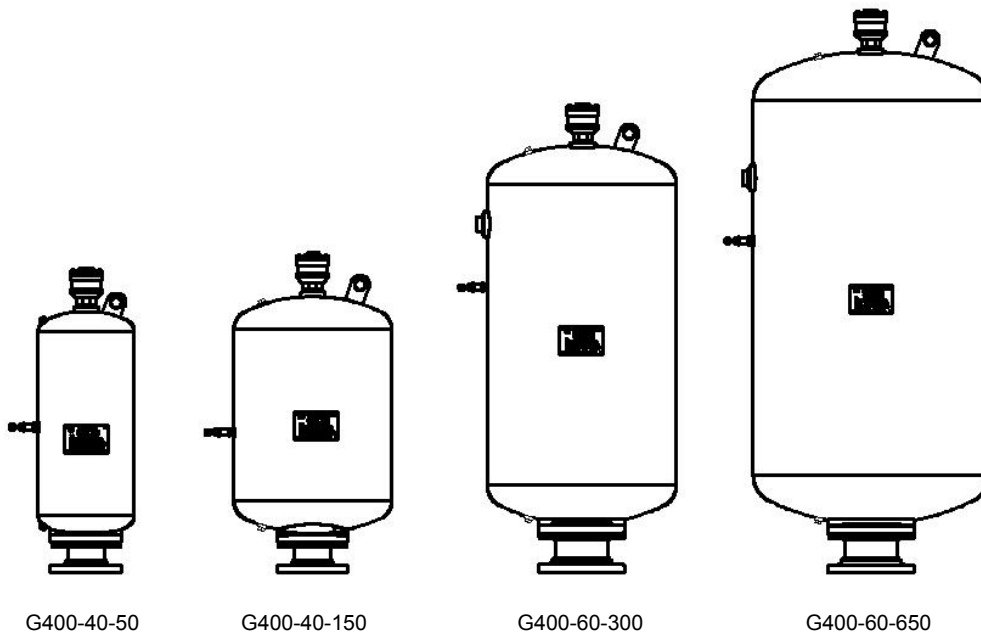



G400 Series Air Cannons Installation and Operating Instructions

ACT FLASH CANNON



Spare Part Suggestions

G400 Series Air Cannons

SPARE PARTS:	Quantity	G400-40-50	G400-40-150	G400-60-300	G400-60-650
Air Cannon:					
Pressure Relief Valve	5%	#290408	#290408	#290408	#290408
Valve Assembly - Complete	5%	#305140	#305140	#305160	#305160
Valve Seat	5%	#304640	#304640	#304660	#304660
Piston	5%	#275245	#275245	#275265	#275265
O-Rings - Complete Set of seven (7)	10%	#386004	#386004	#386006	#386006
Seat - VITON (1)		#386240	#386240	#386431	#386431
Piston - Nose - VITON (1)		#386237	#386237	#386254	#386254
Piston - Body - VITON (1)		#386343	#386343	#386436	#386436
Piston - Damper - VITON (1)		#386208	#386208	#386212	#386212
Cap - Main- VITON (1)		#386343	#386343	#386431	#386431
Cap - Exhaust - VITON (1)		#386331	#386331	#386343	#386343
Cap - Fill Line - VITON (1)		#386118	#386118	#386122	#386122
Retaining Ring	10%	#347400	#347400	#347625	#347625
Gaskets	10%	#296140	#296140	#296160	#296160
Quick Exhaust Valve	5%	#308011	#308011	#308011	#308011
3-Way N/O Solenoid Valve - 110V	5%	#456112	#456112	#456112	#456112
Timer:					
Front Door Circuit Board - 110V	10%	#450801	#450801	#450801	#450801
Panel Circuit Board - 110V	10%	#450802	#450802	#450802	#450802

The life expectancy of ACT G400 Series Flash Cannons is indefinite when operated using dry, clean air at ambient temperatures below 400°F. Actual life will be affected by the quality of the air, environmental conditions, and mounting position.



G400 Series Air Cannons Installation and Operating Instructions



APPENDIX C - AIR CANNON DIMENSIONS

G400 Series Air Cannons

AIR CANNON MODEL		A	B	C	D	E	F	G	H
	WEIGHT	DISCHARGE SIZE	TANK DIAMETER	TANK LENGTH	COUPLING LENGTH	FLANGE DIAMETER	TOTAL LENGTH	TOTAL WIDTH	INLET PORT
	LBS	IN	IN	IN	IN	IN	IN	IN	IN
	KG	MM	MM	MM	MM	MM	MM	MM	NPT
4.0" DISCHARGE:									
G400-40-50	97	4.0	12	28	4.6	9	37.6	13.5	3/4
	44	102	305	711	117	229	955	343	NPT
G400-40-150	131	4.0	20	30	4.6	9	39.6	21.5	3/4
	59	102	508	762	117	229	1006	546	NPT
6.0" DISCHARGE:									
G400-60-300	263	6.0	24	48	6.0	11	59.0	25.6	3/4
	119	152	610	1219	152	279	1499	650	NPT
G400-60-650	557	6.0	30	60	6.0	11	71.0	31.5	3/4
	253	152	762	1524	152	279	1803	800	NPT

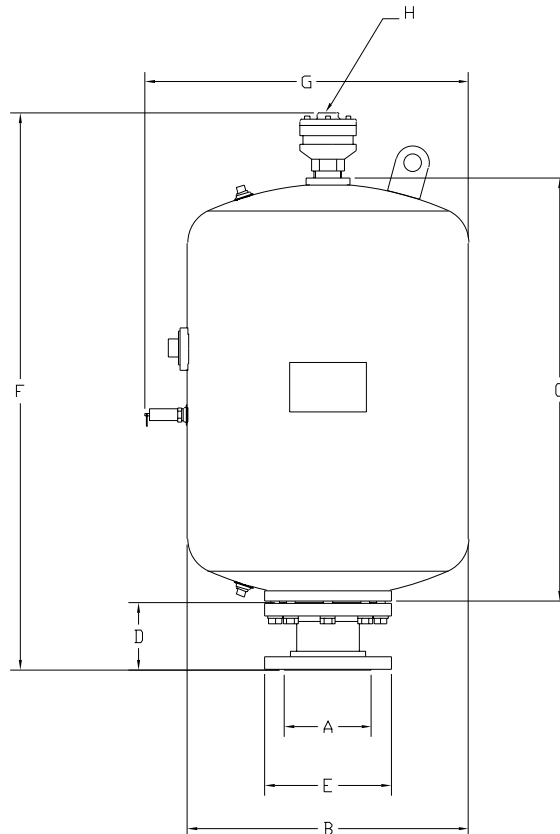



G400 Series Air Cannons Installation and Operating Instructions



APPENDIX D - AIR CANNON PLUMBING DIAGRAMS

Using a Quick Exhaust Valve

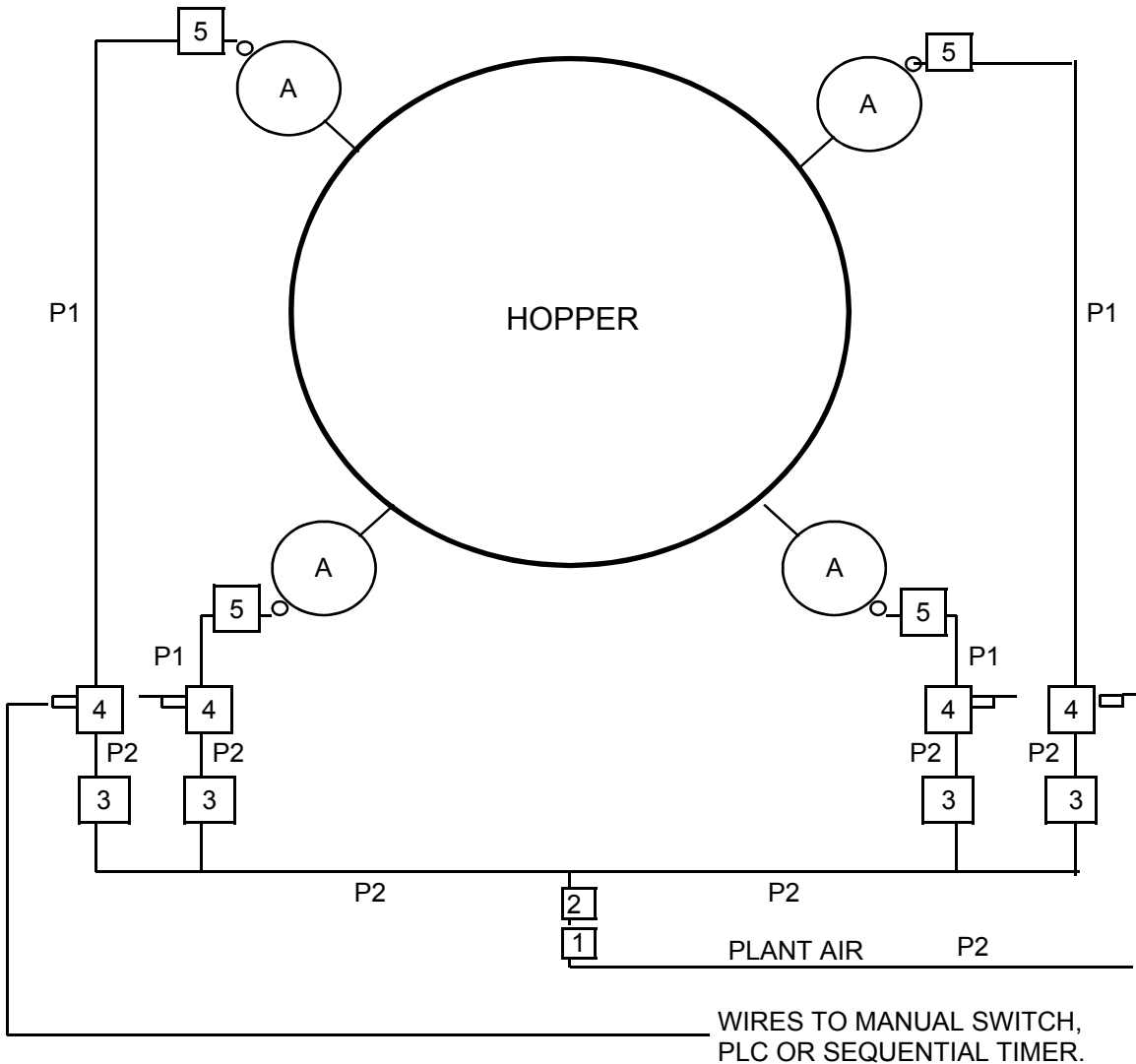

- 1 = 1/2" Shut-off Ball Valve
- 2 = 1/2" Filter-Regulator-Gauge
- 3 = 1/2" Check Valve
- 4 = 3/4" 3-Way N/O Control Valve
- 5 = 1" Quick Exhaust Valve
(3/4" QEV for GW2.5 Air Cannon)
- A = Air Cannon

NOTES:

Airlines & fittings are NPT threads.

P1 = 3/4" Airline rated for 150 psi (10.3 bar)

P2 = 1/2" Airline rated for 150 psi (10.3 bar)

Use one (1) Filter-Regulator for every four (4) Air Cannons.

* This configuration provides optimum Air Cannon performance and allows the control valve (4) to be located up to 100 feet from the Air Cannon.



G400 Series Air Cannons Installation and Operating Instructions

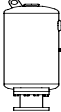
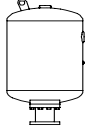
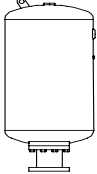
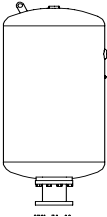

APPENDIX E - AIR CANNON PERFORMANCE DATA

AIR CANNON MODEL	AIR PRESSURE	PSI	70	80	90	100
		BAR	4.8	5.5	6.2	6.9
4.0" DISCHARGE						
 G400-40-50 Tank Volume = 1.7 cu ft (49 l)	FREE AIR VOLUME	CU FT	8.2	9.4	10.5	11.7
		LITERS	232	265	298	331
	FILL TIME	SEC	15	15	15	15
	SHOT TIME	SEC	0.08	0.08	0.09	0.09
	FORCE	LBS	698	851	997	1072
		KN	3.13	3.81	4.47	4.80
	Efficiency	lbs/cuft	85	91	95	92
 G400-40-150 Tank Volume = 5.0 cu ft (142 l)	FREE AIR VOLUME	CU FT	23.8	27.2	30.6	34.0
		LITERS	675	771	868	964
	FILL TIME	SEC	35	40	40	40
	SHOT TIME	SEC	0.16	0.16	0.16	0.20
	FORCE	LBS	1070	1220	1383	1532
		KN	4.80	5.47	6.20	6.87
	Efficiency	lbs/cuft	45	45	45	45
6.0" DISCHARGE						
 G400-60-300 Tank Volume = 10.6 cu ft (299 l)	FREE AIR VOLUME	CU FT	50.2	57.4	64.6	71.7
		LITERS	1422	1625	1828	2031
	FILL TIME	SEC	90	90	90	105
	SHOT TIME	SEC	0.22	0.22	0.22	0.24
	FORCE	LBS	1735	2000	2320	2525
		KN	7.78	8.96	10.40	11.32
	Efficiency	lbs/cuft	35	35	36	35
 G400-60-650 Tank Volume = 22.8 cu ft (645 l)	FREE AIR VOLUME	CU FT	108.5	124.0	139.5	155.0
		LITERS	3073	3511	3950	4389
	FILL TIME	SEC	210	210	210	210
	SHOT TIME	SEC	0.42	0.42	0.46	0.46
	FORCE	LBS	2065	2380	2761	3005
		KN	9.25	10.67	12.37	13.47
	Efficiency	lbs/cuft	19	19	20	19
FILL TIME = Time to fill tank within +/- 2 psi of regulated pressure using 3/8" x 10' fill line. Fill time may vary depending on fill line size and length, compressor characteristics, and environmental conditions.						
FORCE measurements were made using an 8" diameter, 1" thick piston, located 4" from the Air Cannon discharge mount flange, to transfer the blast impulse to a dynamic sensor. A 1" solenoid valve, without muffler, mounted directly to the air inlet port was used to fire the Air Cannons.						
FILL TIME, SHOT TIME, & FORCE for the G400-60-650 were not measured . The data presented is an estimation of performance for this model.						



G400 Series Air Cannons Installation and Operating Instructions



APPENDIX F - AIR CANNON PARTS DRAWINGS

**Models: G400-40-50
G400-40-150**

NO.	DESCRIPTION	PART #	814100		QTY.	NO.	DESCRIPTION	PART #	814300		QTY.
			G400 40-50	G400 40-150					G400 40-50	G400 40-150	
1	Bolt Hex UNC 5/8-11x 1.75 Gr5	331517	331517	331517	8	16	O-Ring VITON 568-118	386118	386118	1	
2	Washer Lock 5/8"	338110	338110	338110	8	17	Retaining Ring 5000-400	347400	347400	1	
3	Coupling	300140	300140	300140	1	18	Tank	306428	307430	1	
4	Gasket High Temperature	296140	296140	296140	1	19	Plug, Solid 1/2" Galv.	295108	295108	2	
5	Valve Assembly	305140	305140	305140	1	20	Valve, Pressure Relief 1/2"	290408	290408	1	
6	Valve Body	302540	302540	302540	1	21	Fill Line 3/4"	260073	260074	1	
7	O-Ring VITON 568-240	386240	386240	386240	1	22	Valve quick exhaust	308011	308011	1	
8	Valve Seat	304640	304640	304640	1						
9	Piston Assembly	275245	275245	275245	1						
10	Piston Assembly w/o O-rings				1						
11	O-Ring VITON 568-237	386237	386237	386237	1						
12	O-Ring VITON 568-343	386343	386343	386343	2						
13	O-Ring VITON 568-208	386208	386208	386208	1						
14	Valve Cap	304240	304240	304240	1						
15	O-Ring VITON 568-331	386331	386331	386331	1						

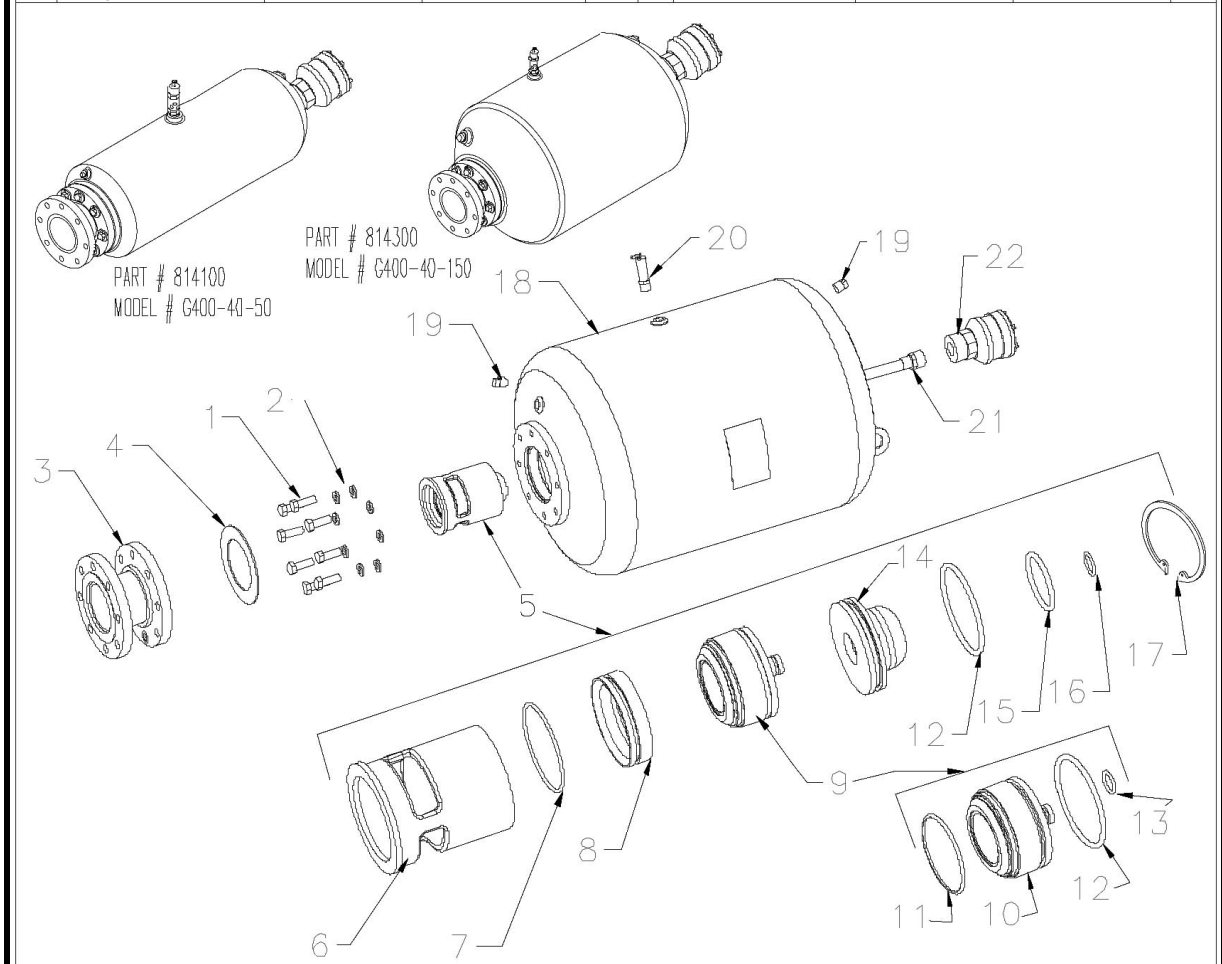



G400 Series Air Cannons Installation and Operating Instructions



APPENDIX F - AIR CANNON PARTS DRAWINGS

**Models: G400-60-300
G400-60-650**

NO.	DESCRIPTION	PART # MODEL #	817400	817420	817500	817520	QTY.	NO.	DESCRIPTION	PART # MODEL #	817400	817420	817500	817520	QTY.
			G400 60-300	G400 60-300-4	G400 60-650	G400 60-650-4					G400 60-300	G400 60-300-4	G400 60-650	G400 60-650-4	
1	Bolt Hex 3/4-10-2" GR5		331620	331620	331620	331620	8	16	O-Ring VITON 568-122		386122	386122	386122	386122	1
2	Washer Lock 3/4" PLATED		338112	338112	338112	338112	8	17	Retaining Ring 5000-625		347625	347625	347625	347625	1
3	Coupling		300160	300164	300160	300164	1	18	Fill Line 1"		260076	260076	260077	260077	1
4	Gasket High Temperature		296160	296160	296160	296160	1	19	Plug, Solid 1/2" Galv.		295108	295108	295108	295108	2
5	Valve Assembly		305160	305160	305160	305160	1	20	Tank		307648	307648	307660	307660	1
6	Valve Body		302560	302560	302560	302560	1	21	Valve, Pressure Relief 1/2"		290408	290408	290408	290408	1
7	O-Ring VITON 568-431		386431	386431	386431	386431	2	22	Valve quick exhaust		308011	308011	308011	308011	1
8	Valve Seat		304660	304660	304660	304660	1	23	Plug, Black Cast 2"		295232	295232	295232	295232	1
9	Piston Assembly		275265	275265	275265	275265	1								
10	Piston Assembly w/o O-Rings						1								
11	O-Ring VITON 568-254		386254	386254	386254	386254	1								
12	O-Ring VITON 568-436		386436	386436	386436	386436	1								
13	O-Ring VITON 568-212		386212	386212	386212	386212	1								
14	Valve Cap		304260	304260	304260	304260	1								
15	O-Ring VITON 568-343		386343	386343	386343	386343	1								

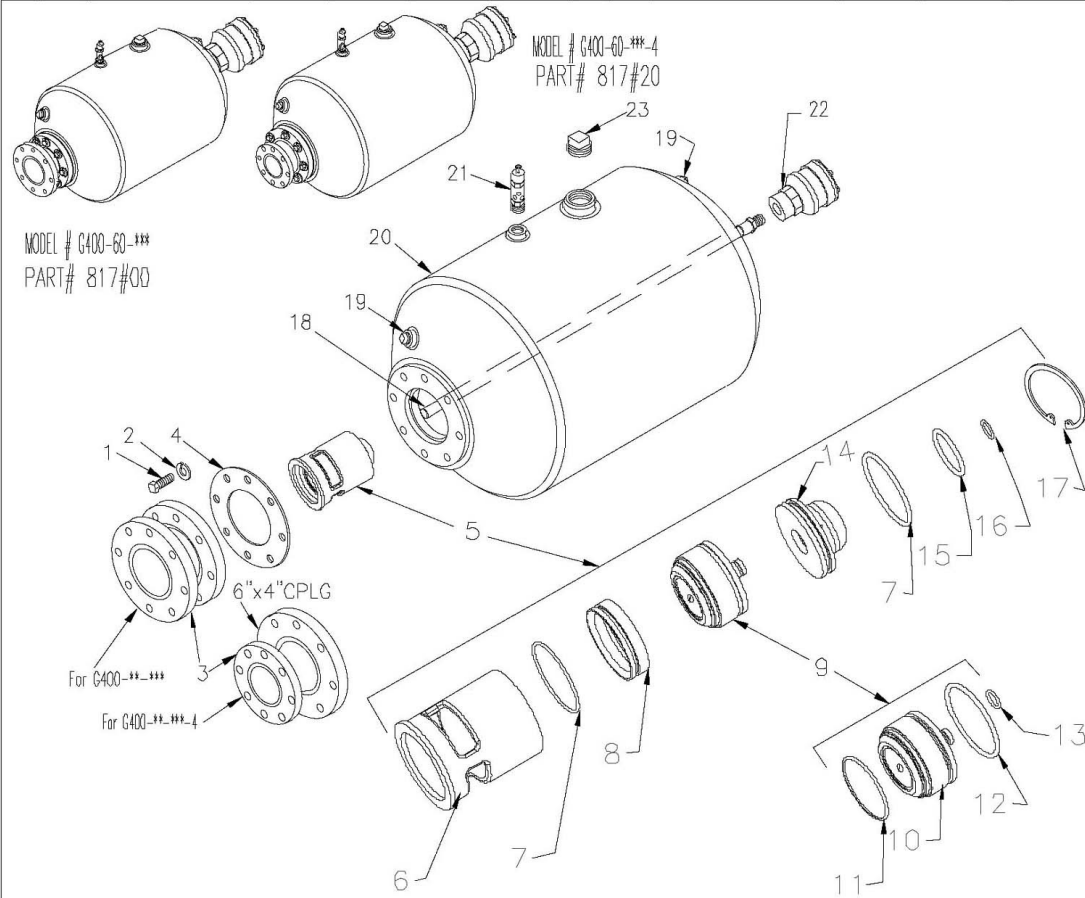



G400 Series Air Cannons Installation and Operating Instructions



APPENDIX G - COORDINATES & DIMENSIONS OF ELLIPTICAL OPENINGS FOR TANGENTIAL MOUNTS

Coordinates and dimensions of elliptical openings for:			
2.5" PIPE			
	X	Y	
A	-1.59	0.58	
B	1.22	3.34	
C	1.59	-0.58	
D	-1.22	-3.34	
w			3.37
h			7.12
4" PIPE			
A	-2.35	0.86	
B	1.77	4.87	
C	2.35	-0.85	
D	-1.77	-4.87	
w			5.00
h			10.37
6" PIPE			
A	-3.25	1.22	
B	2.50	6.87	
C	3.35	-1.22	
D	-2.50	-6.87	
w			7.12
h			14.62

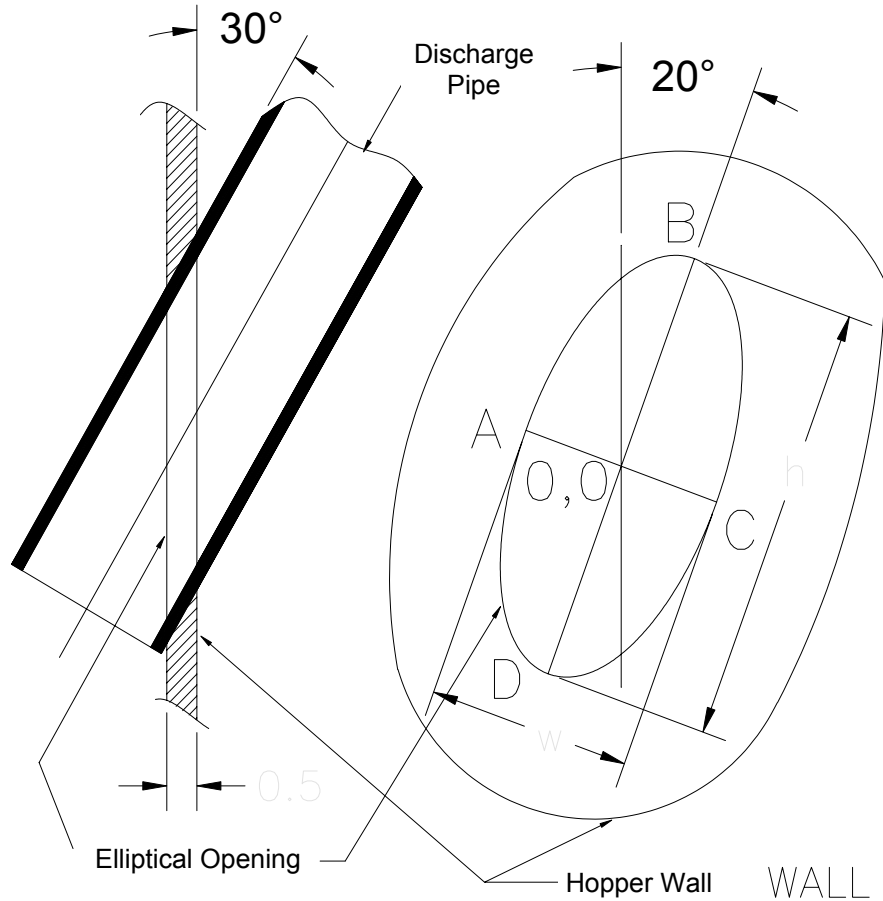



G400 Series Air Cannons Installation and Operating Instructions



APPENDIX H - MOUNTING G400 AIR CANNONS ON HIGH TEMPERATURE APPLICATIONS

G400 Air Cannons are made for use on high temperature applications such as cement kilns and steel mills. They can withstand ambient temperatures of 400°F (200°C). Exposure to temperatures in excess of 400°F will cause the piston to seize. Damage caused by operating G400 Air Cannons at temperatures in excess of 400°F are not covered by the product warranty. When mounting on cement kilns, **the discharge pipe must be long enough to ensure temperatures at the Air Cannon valve are below 400°F**. For cement kilns with temperatures of 2,000°F (1,100°C), it is recommended that the discharge should extend **at least 36"** beyond the outer wall of the kiln and have **at least one long radius bend**. The diagrams below show several acceptable mounting configurations.

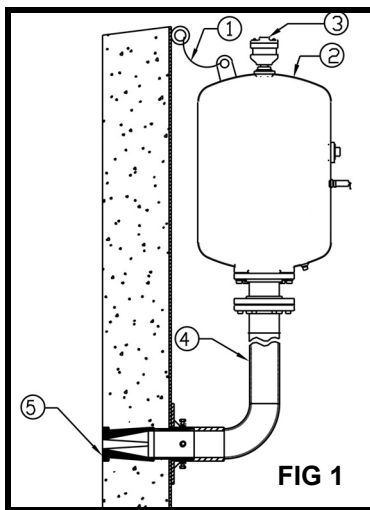

FIG 1 - G400-40-150 Flash Cannon (2) with standard G-Series Quick Exhaust Valve (3) mounted on an ACT 4HT90LW discharge assembly (4). The discharge assembly includes a long radius bend, a mount flange for the Air Cannon, & a mount plate that can be welded to the side of the kiln. The mount plate allows the Global 4HTP stainless steel straight nozzle (5) to be replaced without dismantling the Air Cannon. (1) is an ACT safety cable kit with 14' of aircraft cable.

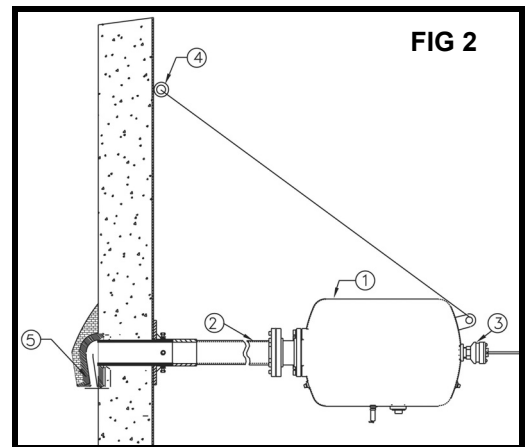

FIG 2 - G400-40-150 Flash Cannon (1) with standard G-Series Quick Exhaust Valve (3) mounted on an ACT 4HT straight discharge assembly (2). The discharge assembly has no long radius bend, but provides 42" of pipe for adequate heat dissipation. The discharge assembly includes a mount flange for the Flash Cannon & a mount plate that can be welded to the side of the kiln. The mount plate allows the ACT 4HTPA stainless steel adjustable angled nozzle (5) to be replaced without dismantling the Flash Cannon. (4) is an ACT safety cable kit with 14' of aircraft cable.

FIG 3 - G400-40-150 Flash Cannon with standard G-Series Quick Exhaust Valve mounted on an ACT 4HTP stainless steel straight nozzle with custom length of 4" stainless steel discharge pipe. A standard 4" slip on flange is used to attach the Flash Cannon to the pipe and an ACT 60° down-ward tilt weld on mount plate is used to secure the discharge assembly to the kiln wall. An ACT safety cable kit with 14' of aircraft cable is used.

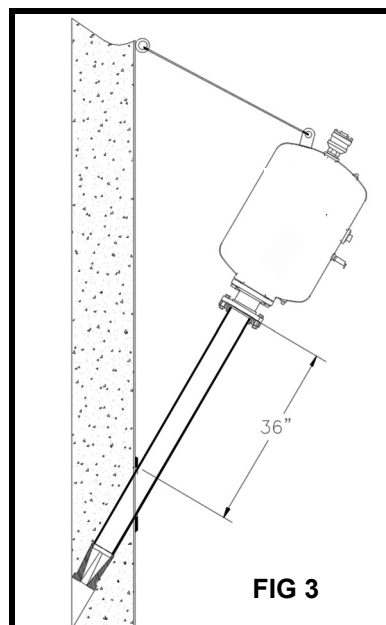

FIG 3